

CLUTCH

SECTION **CL**

CONTENTS

PRECAUTIONS	CL- 2
PREPARATION	CL- 3
CLUTCH SYSTEM	CL- 4
INSPECTION AND ADJUSTMENT	CL- 5
HYDRAULIC CLUTCH CONTROL	CL- 6
CLUTCH RELEASE MECHANISM	CL-10
CLUTCH DISC AND CLUTCH COVER	CL-12
SERVICE DATA AND SPECIFICATIONS (S.D.S.)	CL-15



PRECAUTIONS

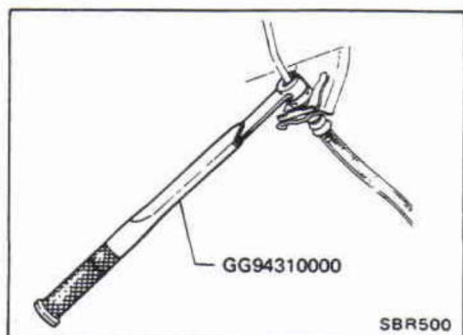

Precautions

- Recommended fluid is brake fluid "DOT 3".
- Never reuse drained brake fluid.
- Be careful not to splash brake fluid on painted areas.
- When removing and installing clutch piping, use Tool.
- Use new brake fluid to clean or wash all parts of master cylinder, operating cylinder and clutch damper.
- Never use mineral oils such as gasoline or kerosene. It will ruin the rubber parts of the hydraulic system.





WARNING:

After cleaning the clutch disc, wipe it with a dust collector. Do not use compressed air.

PREPARATION

SPECIAL SERVICE TOOLS

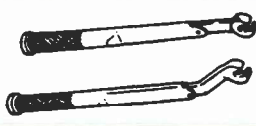
*: Special tool or commercial equivalent

Tool number Tool name	Description	
ST20050010 Base plate		Inspecting diaphragm spring of clutch cover
ST20050100 Distance piece		Inspecting diaphragm spring of clutch cover
GG94310000* Flare nut torque wrench		Removing and installing each clutch piping
ST20600000* (KV30100100) Clutch aligning bar		Installing clutch cover and clutch disc
ST20050240* Diaphragm spring adjusting wrench		Adjusting unevenness of diaphragm spring of clutch cover

COMMERCIAL SERVICE TOOL

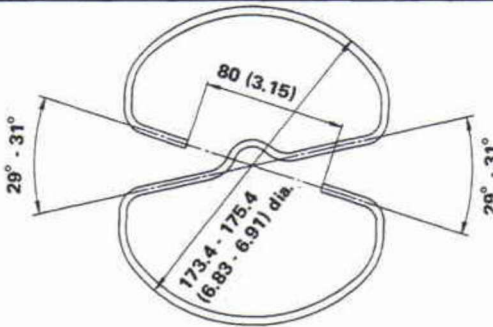
Tool name	Description	
Wire		Installing clutch cover Wire: 3.2 (0.126) dia. Unit: mm (in)

CLUTCH SYSTEM

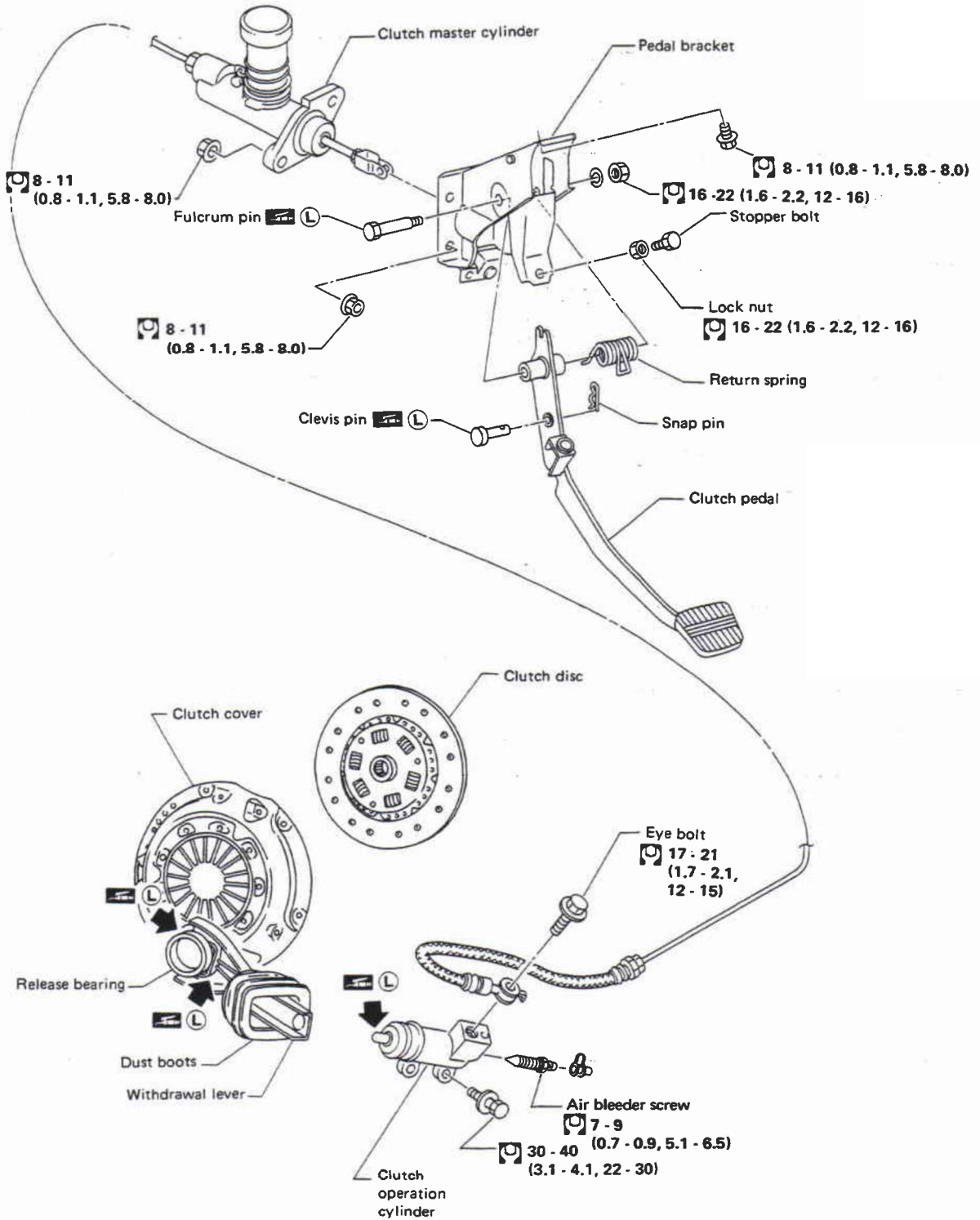

: Apply lithium-based grease including molybdenum disulphide.
 : N·m (kg·m, ft·lb)

SCL328

CL-4

INSPECTION AND ADJUSTMENT

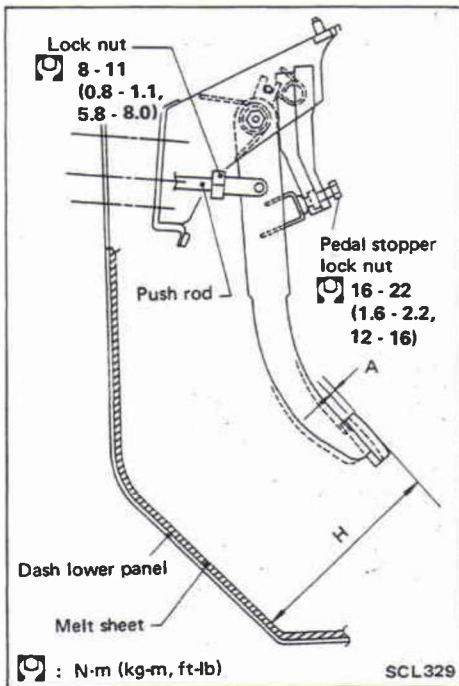

Adjusting Clutch Pedal

1. Adjust pedal height with pedal stopper.

Pedal height "H*":

202 - 212 mm (7.95 - 8.35 in)

*: Measured from surface of melt sheet to pedal pad

2. Adjust pedal free play with master cylinder push rod or clutch booster input rod. Then tighten lock nut.

Pedal free play "A":

1.0 - 3.0 mm (0.039 - 0.118 in)

Pedal free play means the following total measured at position of pedal pad:

- Play due to clevis pin and clevis pin hole in clutch pedal.
- Play due to piston and push rod.

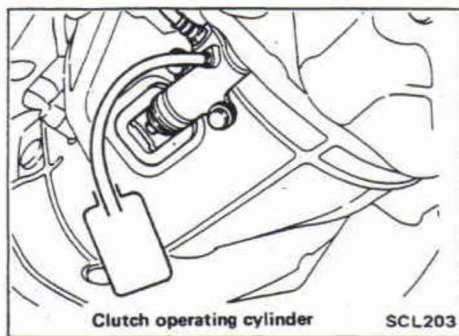

Bleeding Procedure

- **Carefully monitor fluid level at master cylinder during bleeding operation.**

1. Top up reservoir tank with recommended brake fluid.
2. Connect a transparent vinyl tube to air bleeder valve.
3. Fully depress clutch pedal several times.
4. With clutch pedal depressed, open bleeder valve to release air.
5. Close bleeder valve.
6. Repeat steps 4 through 6 above until clear brake fluid comes out of air bleeder valve.

HYDRAULIC CLUTCH CONTROL

Clutch Master Cylinder

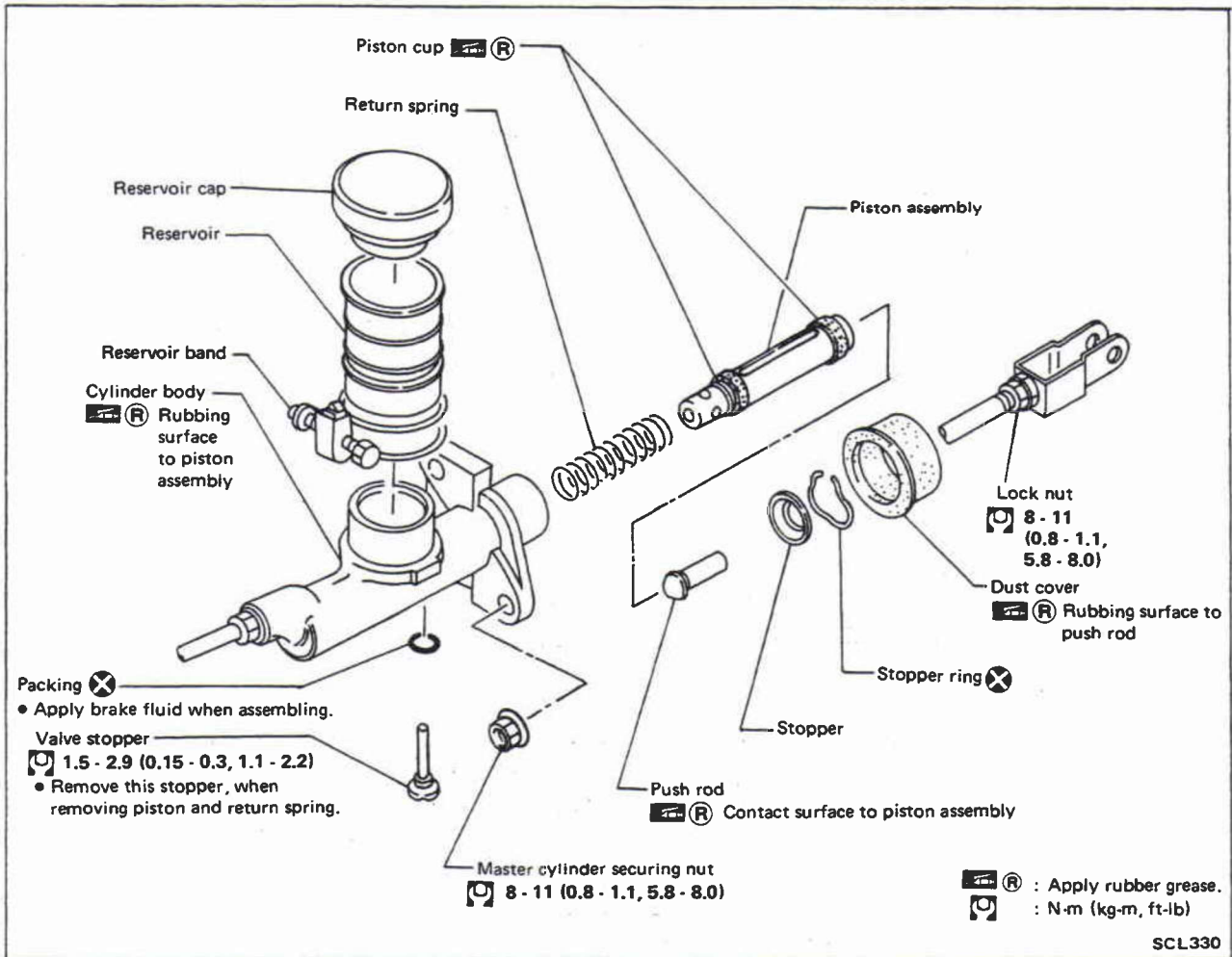

DISASSEMBLY AND ASSEMBLY

- Push piston in cylinder body with screwdriver when removing and installing valve stopper.

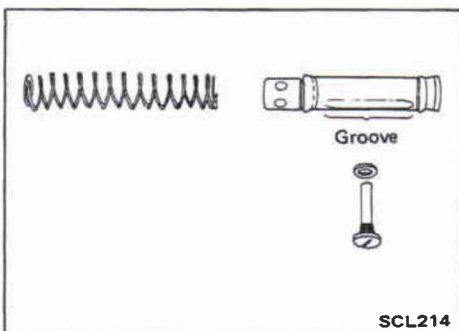

- Align groove of piston assembly and valve stopper portion when installing valve stopper.
- Check direction of piston caps.

HYDRAULIC CLUTCH CONTROL

Clutch Master Cylinder (Cont'd)

INSPECTION

- Check cylinder and piston rubbing surface for uneven wear, rust or damage. Replace if necessary.
- Check piston with piston cup for wear or damage. Replace if necessary.
- Check return spring for wear or damage. Replace if necessary.
- Check reservoir for deformation or damage. Replace if necessary.
- Check dust cover for cracks, deformation or damage. Replace if necessary.

Clutch Operating Cylinder

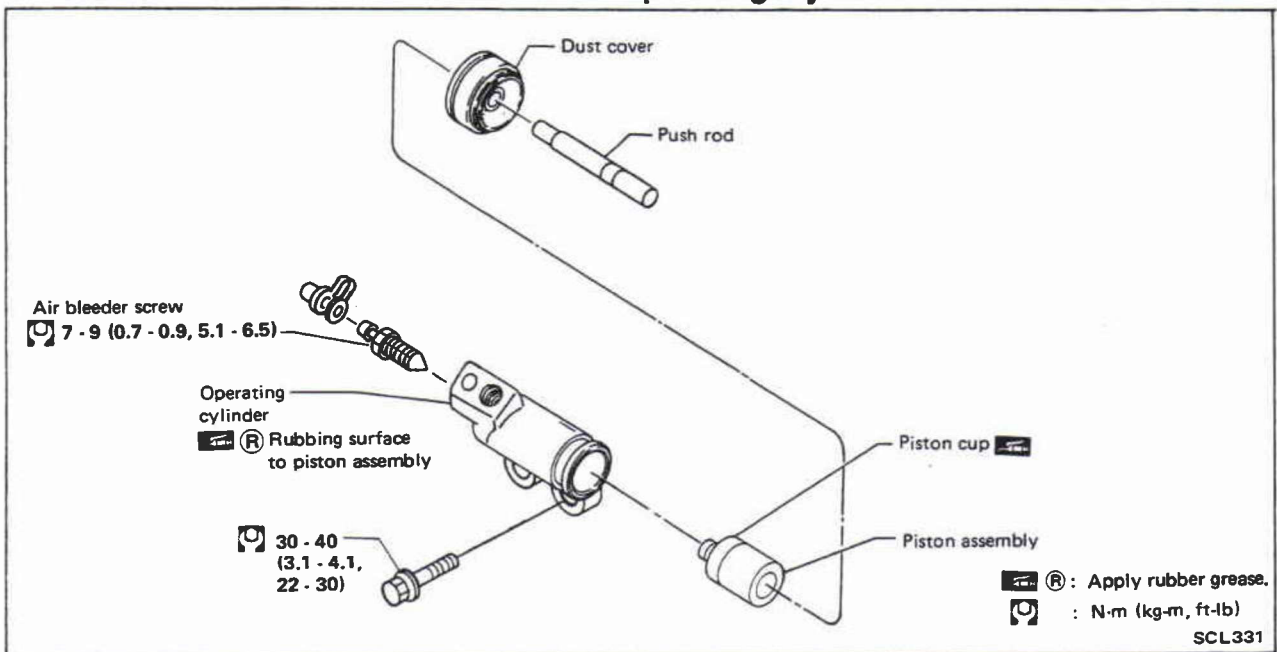

INSPECTION

- Check rubbing surface of cylinder for wear, rust or damage. Replace if necessary.
- Check piston with piston cup for wear or damage. Replace if necessary.
- Check dust cover for cracks, deformation or damage. Replace if necessary.

HYDRAULIC CLUTCH CONTROL

Clutch Booster

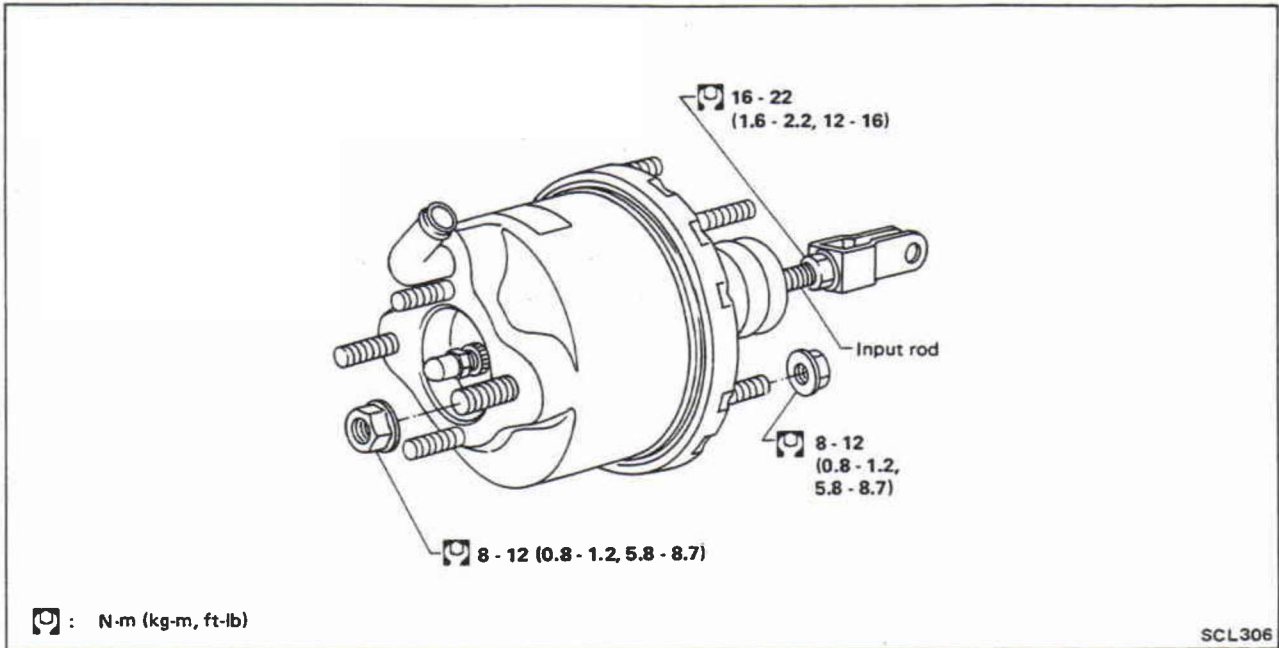

INSPECTION

Hoses and connectors

- Check condition of vacuum hoses and connections.
- Check vacuum hoses and check valve for air tightness.

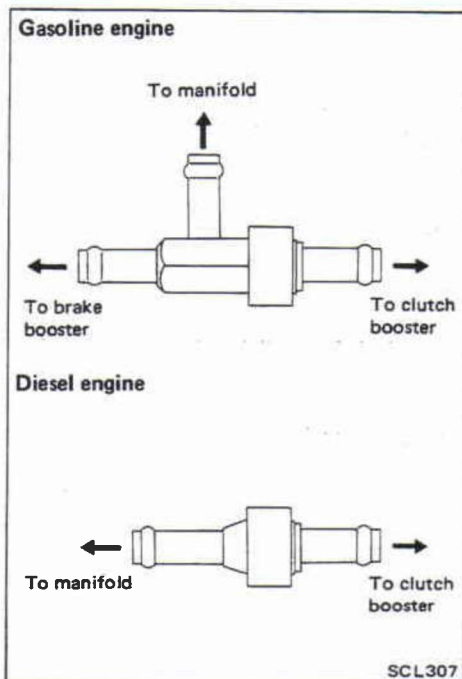

Check valve

- Install check valve properly paying attention to its direction.

HYDRAULIC CLUTCH CONTROL

Clutch Booster (Cont'd)

- When pressure is applied to the clutch booster side of check valve and valve does not open, replace check valve with a new one.

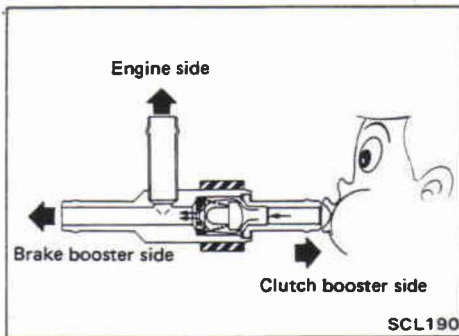

ADJUSTMENT

Output rod length:

Length "A"

1.30 - 1.55 mm (0.0512 - 0.0610 in)

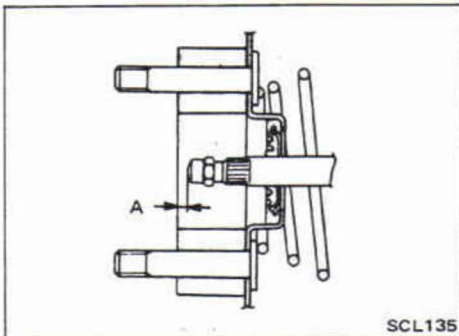

If amount of adjustment required exceeds 0.5 mm (0.020 in), reaction disc may have either been dislocated or fallen off. Replace clutch booster assembly.

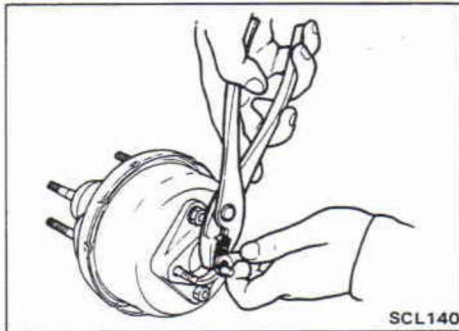

Input rod length:

Length "B"

130 mm (5.12 in)

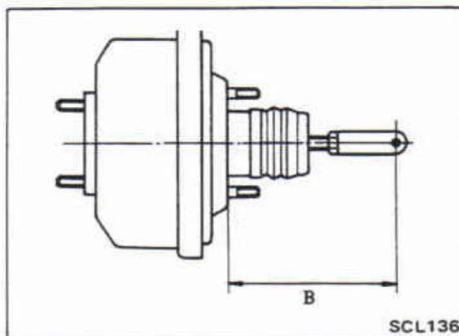

CLUTCH RELEASE MECHANISM

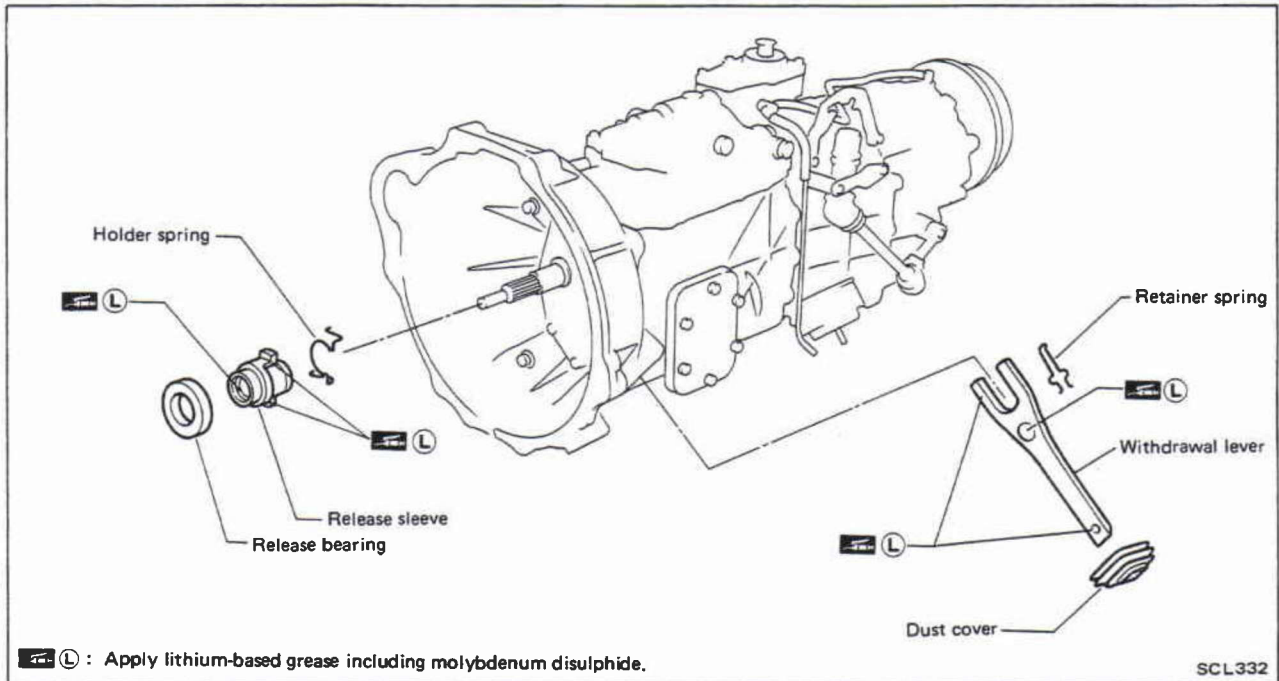

REMOVAL AND INSTALLATION

- Install retainer spring and holder spring.

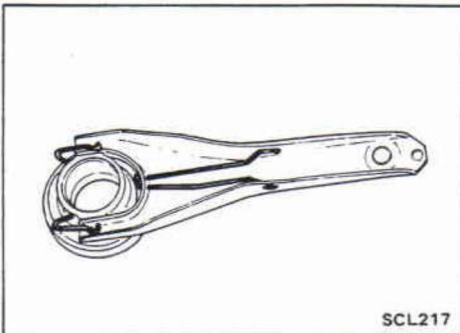

- Remove release bearing.

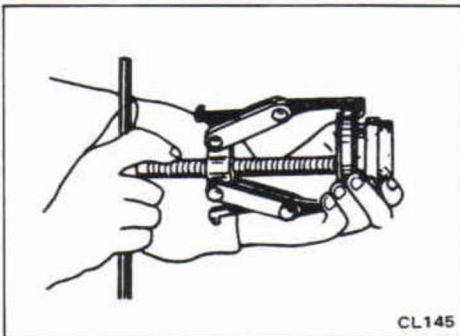

- Install release bearing with suitable drift.

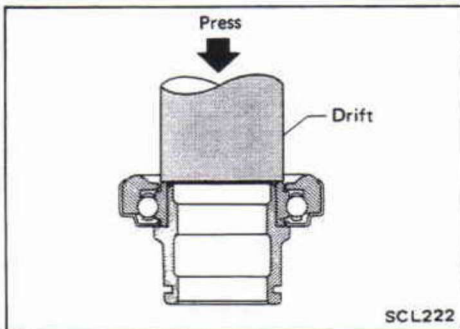

CLUTCH RELEASE MECHANISM

INSPECTION

- Check release bearing to see that it rolls freely and is free from noise, crack, pitting or wear. Replace if necessary.
- Check release sleeve and withdrawal lever rubbing surface for wear, rust or damage. Replace if necessary.

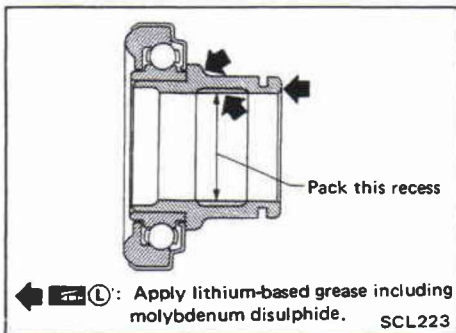

LUBRICATION

- Apply recommended grease to contact surface and rubbing surface.

Too much lubricant might cause clutch disc facing damage.

CLUTCH DISC AND CLUTCH COVER

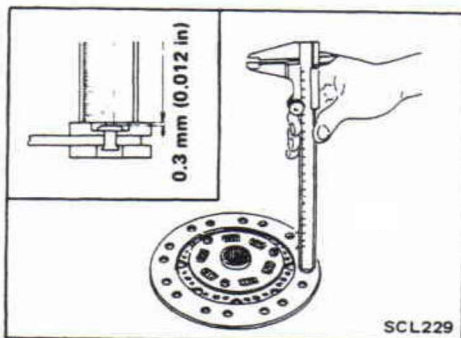
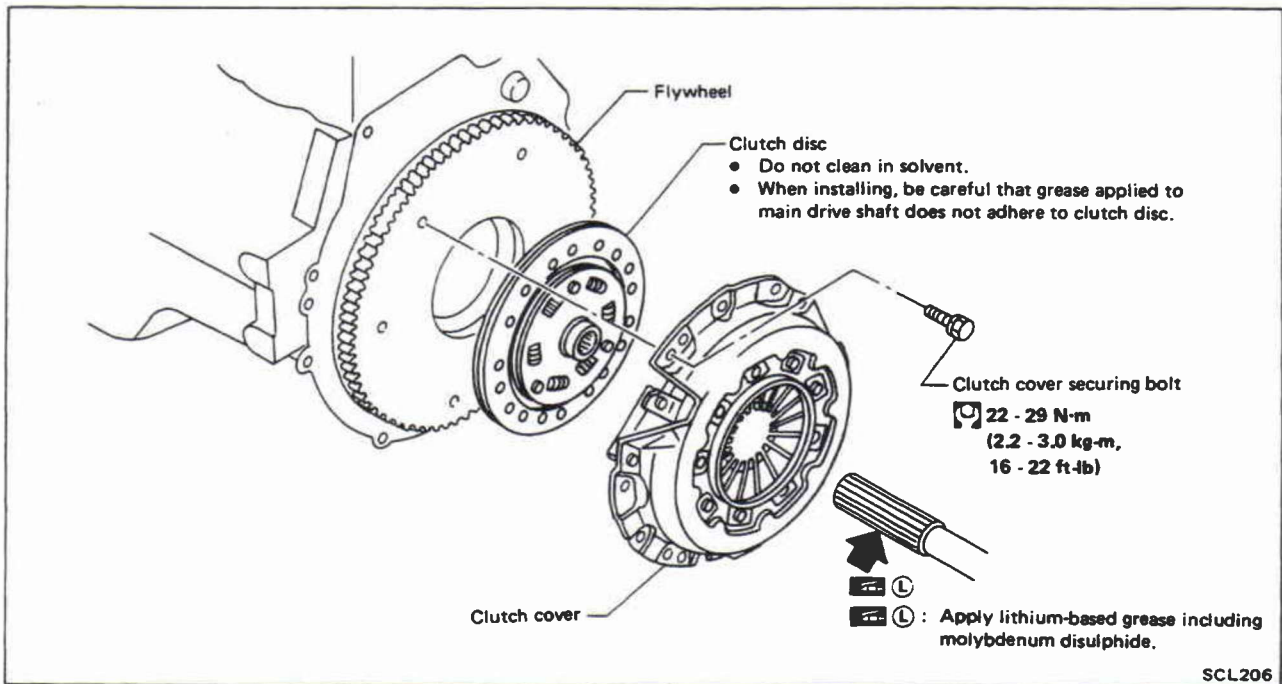

Clutch Disc INSPECTION

Check clutch disc for wear of facing.

**Wear limit of facing surface to rivet head:
0.3 mm (0.012 in)**

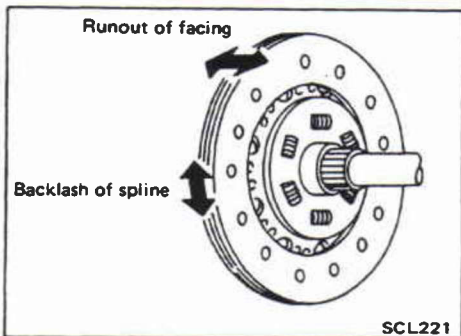

- Check clutch disc for backlash of spline and runout of facing.

**Maximum backlash of spline (at outer edge of disc):
1.1 mm (0.043 in)**

**Runout limit:
1.3 mm (0.051 in)**

**Distance of runout check point (from hub center)
132.5 mm (5.22 in)**

- Check clutch disc for burns, discoloration or oil or grease leakage. Replace if necessary.

INSTALLATION

- Apply recommended grease to contact surface of spline portion.

Too much lubricant might cause clutch disc facing damage.

CLUTCH DISC AND CLUTCH COVER

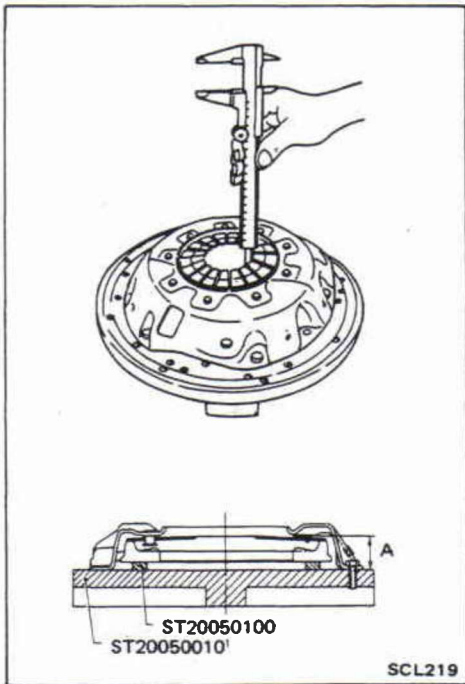

Clutch Cover and Flywheel INSPECTION

- Set Tool and check height and unevenness of diaphragm spring.

Diaphragm spring height "A":

44 - 46 mm (1.73 - 1.81 in)

- Check thrust rings for wear or damage by shaking cover assembly up and down to listen for chattering noise, or lightly hammering on rivets for a slightly cracked noise. Replace clutch cover assembly if necessary.
- Check pressure plate and clutch disc contact surface for slight burns or discoloration. Repair pressure plate with emery paper.
- Check pressure plate and clutch disc contact surface for deformation or damage. Replace if necessary.

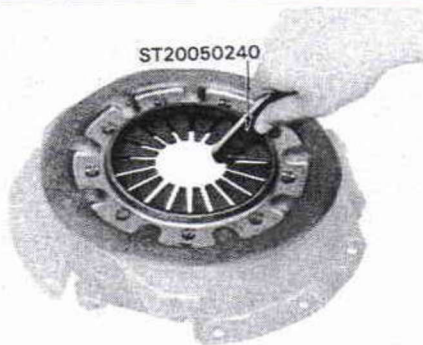

- Adjust unevenness of diaphragm spring with Tool.

Uneven limit:

0.5 mm (0.020 in)

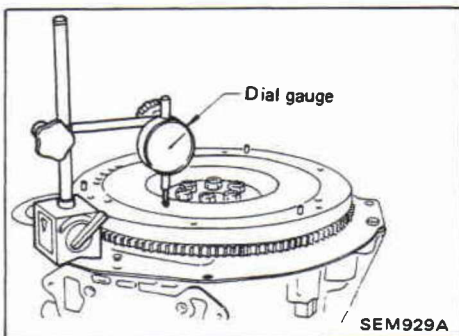

- Check flywheel and clutch disc contact surface for slight burns or discoloration. Repair flywheel with emery paper.
- Check flywheel runout.

Runout (Total indicator reading):

TD42 engine model

0.15 mm (0.0059 in) or less

TB42 engine model

0.1 mm (0.004 in) or less

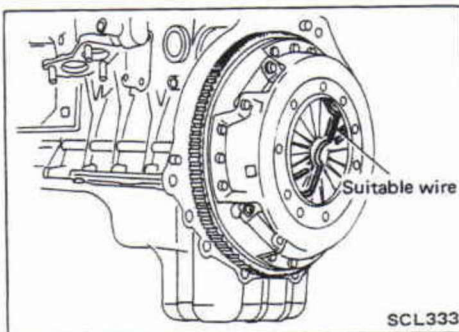

INSTALLATION

- Use suitable wire when installing clutch cover.

CLUTCH DISC AND CLUTCH COVER

Clutch Cover and Flywheel (Cont'd)

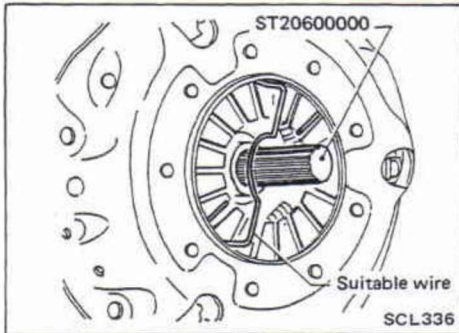

- Insert Tool into clutch disc hub when installing clutch cover and disc.

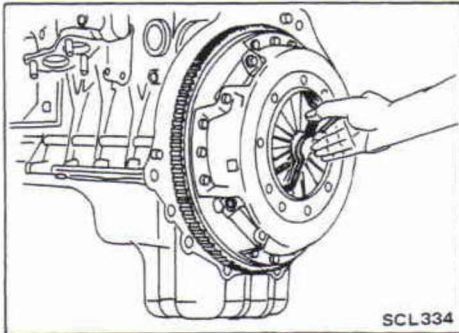

- Remove wire after installing clutch cover and disc.

SERVICE DATA AND SPECIFICATIONS (S.D.S.)

General Specifications

CLUTCH CONTROL SYSTEM

Type of clutch control	Hydraulic
------------------------	-----------

CLUTCH MASTER CYLINDER

Inner diameter	mm (in)	15.87 (5/8)
----------------	---------	-------------

CLUTCH OPERATING CYLINDER

Engine	TD42, TB42	
Inner diameter	mm (in)	19.05 (3/4)

CLUTCH BOOSTER

Engine	TB42	TD42
Type	M45	
Diaphragm diameter	mm (in)	114.3 (4.50)
Check valve type	Double check valve	Single check valve

CLUTCH DISC

Model	275TBL	
Engine	TD42, TB42	
Facing size (Outer dia. x inner dia. x thickness)	mm (in) 275 x 180 x 3.5 (10.83 x 7.09 x 0.138)	
Thickness of disc assembly With load	mm (in)/N (kg, lb) 7.8 - 8.2 (0.307 - 0.323)/ 5,394 (550, 1,213)	

CLUTCH COVER

Model	D275K		
Engine	TD42	TB42	
Full load	N (kg, lb)	5,394 (550, 1,213)	5,884 (600, 1,323)

Inspection and Adjustment

CLUTCH PEDAL

Unit: mm (in)

Pedal height "H"	202 - 212 (7.95 - 8.35)
Pedal free play "A"	1.0 - 3.0 (0.039 - 0.118)

*: Measured from surface of melt sheet to pedal pad

CLUTCH BOOSTER

Output rod length "A"	mm (in)	1.30 - 1.55 (0.0512 - 0.0610)
Input rod length "B"	mm (in)	130 (5.12)

CLUTCH DISC

Unit: mm (in)

Model	275TBL
Wear limit of facing surface to rivet head	0.3 (0.012)
Runout limit of facing	1.3 (0.051)
Distance of runout check point (from the hub center)	132.5 (5.22)
Maximum backlash of spline (at outer edge of disc)	1.1 (0.043)

CLUTCH COVER

Unit: mm (in)

Model	D275K
Diaphragm spring height	0.5 (0.020)
Uneven limit of diaphragm spring toe height "A"	44 - 46 (1.73 - 1.81)