

PROPELLER SHAFT & DIFFERENTIAL CARRIER

SECTION **PD**

CONTENTS



PREPARATION	PD- 2
PROPELLER SHAFT	PD- 6
ON-VEHICLE SERVICE (Final Drive)	PD-11
REMOVAL AND INSTALLATION	PD-12
FINAL DRIVE	PD-13
DISASSEMBLY	PD-14
INSPECTION	PD-19
ADJUSTMENT	PD-20
ASSEMBLY	PD-23
LIMITED SLIP DIFFERENTIAL (For H260)	PD-29
SERVICE DATA AND SPECIFICATIONS (S.D.S.)	PD-35

PD

PREPARATION

SPECIAL SERVICE TOOLS

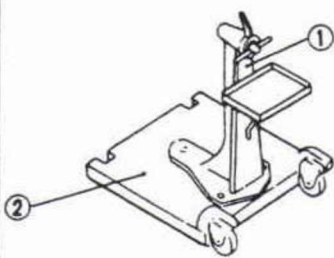

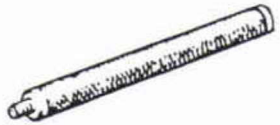
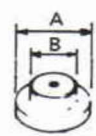
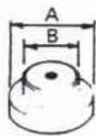
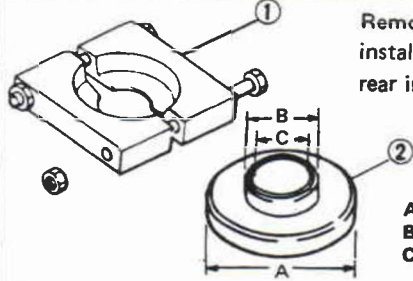
*: Special tool or commercial equivalent

Tool number Tool name	Description	Unit application		
		H260	H233B	
ST0501S000 Engine stand ① ST05011000 Engine stand ② ST05012000 Base		Mounting differential attachment	X	X
ST06340000 Differential attachment		Mounting final drive	-	X
ST06350000 Differential attachment		Mounting final drive	X	-
ST30611000* Drive pinion bearing outer race drift bar		Installing pinion rear bearing outer race	X	X
ST30613000* Drive pinion front bearing outer race drift		Installing pinion front bearing outer race A: 71.5 mm (2.815 in) dia. B: 47.5 mm (1.870 in) dia.	-	X
ST30621000* Drive pinion rear bearing outer race drift		Installing pinion rear bearing outer race A: 79 mm (3.11 in) dia. B: 59 mm (2.32 in) dia.	-	X**
ST3090S000 Drive pinion rear bearing inner race puller set ① ST30031000 Puller ② ST30911000 Base		Removing and installing drive pinion rear inner race	X	X

** : For front differential carrier only

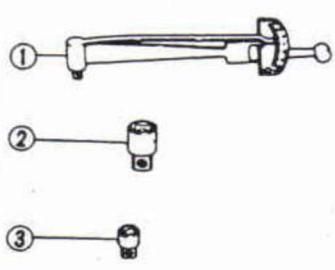
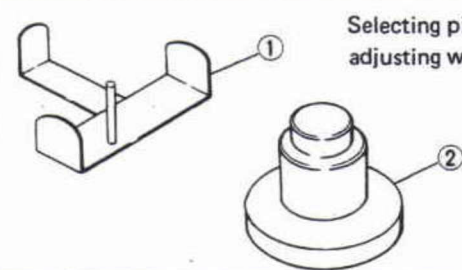
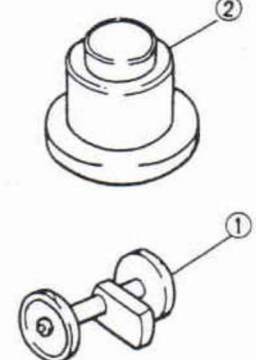

PREPARATION

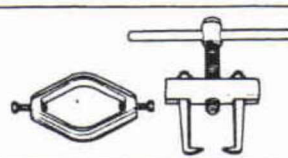
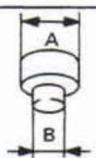
*: Special tool or commercial equivalent

Tool number Tool name	Description	Unit application	
		H260	H233B
ST3127S000 Preload gauge ① GG91030000 Torque wrench ② HT62900000 Socket adapter (1/2") ③ HT62940000 Socket adapter (3/8")	 <p>Measuring pinion bearing preload and total preload</p>	X	X
ST3124S000 Drive pinion setting gauge set ① ST31130000 Height gauge ② ST31241000 Dummy shaft	 <p>Selecting pinion height adjusting washer</p>	X	-
ST3125S000 Drive pinion setting gauge set ① ST31251000 Drive pinion height gauge ② ST31181001 Dummy shaft	 <p>Selecting pinion height adjusting washer</p>	-	X
KV38104700 Drive pinion flange wrench		X	-
KV40104000		-	X
ST33051001* Diff. side bearing puller	 <p>Removing side bearing inner race</p>	X	X
ST02371000* Adapter	 <p>Installing side bearing inner race</p> <p>A: 50 mm (1.97 in) dia. B: 40 mm (1.57 in) dia.</p>	X	-



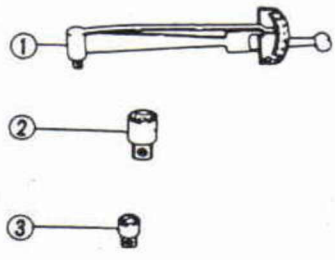
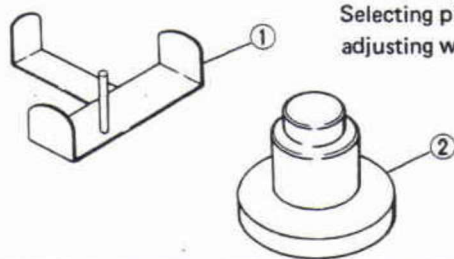
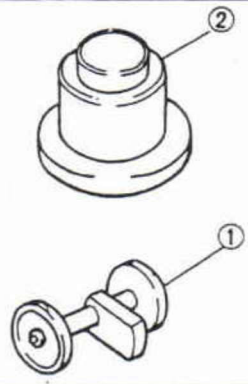

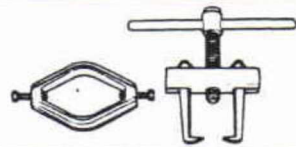
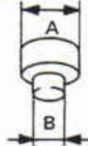

PREPARATION

*: Special tool or commercial equivalent

Tool number Tool name	Description	Unit application	
		H260	H233B
ST3127S000 Preload gauge ① GG91030000 Torque wrench ② HT62900000 Socket adapter (1/2") ③ HT62940000 Socket adapter (3/8")	 <p>Measuring pinion bearing preload and total preload</p>	X	X
ST3124S000 Drive pinion setting gauge set ① ST31130000 Height gauge ② ST31241000 Dummy shaft	 <p>Selecting pinion height adjusting washer</p>	X	-
ST3125S000 Drive pinion setting gauge set ① ST31251000 Drive pinion height gauge ② ST31181001 Dummy shaft	 <p>Selecting pinion height adjusting washer</p>	-	X
KV38104700 Drive pinion flange wrench		X	-
KV40104000		-	X
ST33051001* Diff. side bearing puller	 <p>Removing side bearing inner race</p>	X	X
ST02371000* Adapter	 <p>Installing side bearing inner race</p> <p>A: 50 mm (1.97 in) dia. B: 40 mm (1.57 in) dia.</p>	X	-

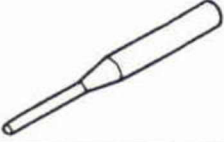
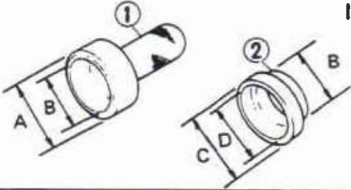
PREPARATION

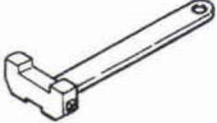
*: Special tool or commercial equivalent

Tool number Tool name	Description	Unit application	
		H260	H233B
ST33081000* Adapter	 <p>Installing side bearing inner race</p> <p>A: 43 mm (1.69 in) dia. B: 33.5 mm (1.319 in) dia.</p>	-	X
ST33230000* Diff. side bearing drift	 <p>Installing side bearing inner race</p> <p>A: 51 mm (2.01 in) dia. B: 28.5 mm (1.122 in) dia.</p>	-	X
KV31100300 Fork rod pin punch		X	X
KV381025S0* Oil seal fitting tool ① ST30720000 Drift bar ② KV38102510 Drift	 <p>Installing front oil seal</p> <p>A: 77 mm (3.03 in) dia. B: 55 mm (2.17 in) dia. C: 71 mm (2.80 in) dia. D: 65 mm (2.56 in) dia.</p>	X	X
ST32580000 Diff. side bearing adjusting nut wrench	 <p>Adjusting side bearing preload and backlash (ring gear-drive pinion)</p>	-	X
ST32530000 Diff. side bearing adjusting nut wrench		X	-
KV38106400 Rear axle shaft dummy (Use 2 pieces per unit)	 <p>Checking differential torque on limited slip differential</p>	X	-
KV38106900		X**	-

** : Pickup model destined for Middle East

PREPARATION

COMMERCIAL SERVICE TOOL

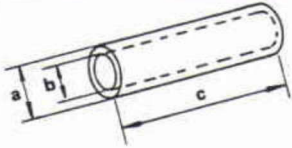
Tool name	Description	Unit application	
		H260	H233B
Drift	 <p>Installing side bearing</p> <p>a = 64 mm (2.52 in) dia. b = 56 mm (2.20 in) dia. c = 160 mm (6.30 in)</p>	X	-

PROPELLER SHAFT

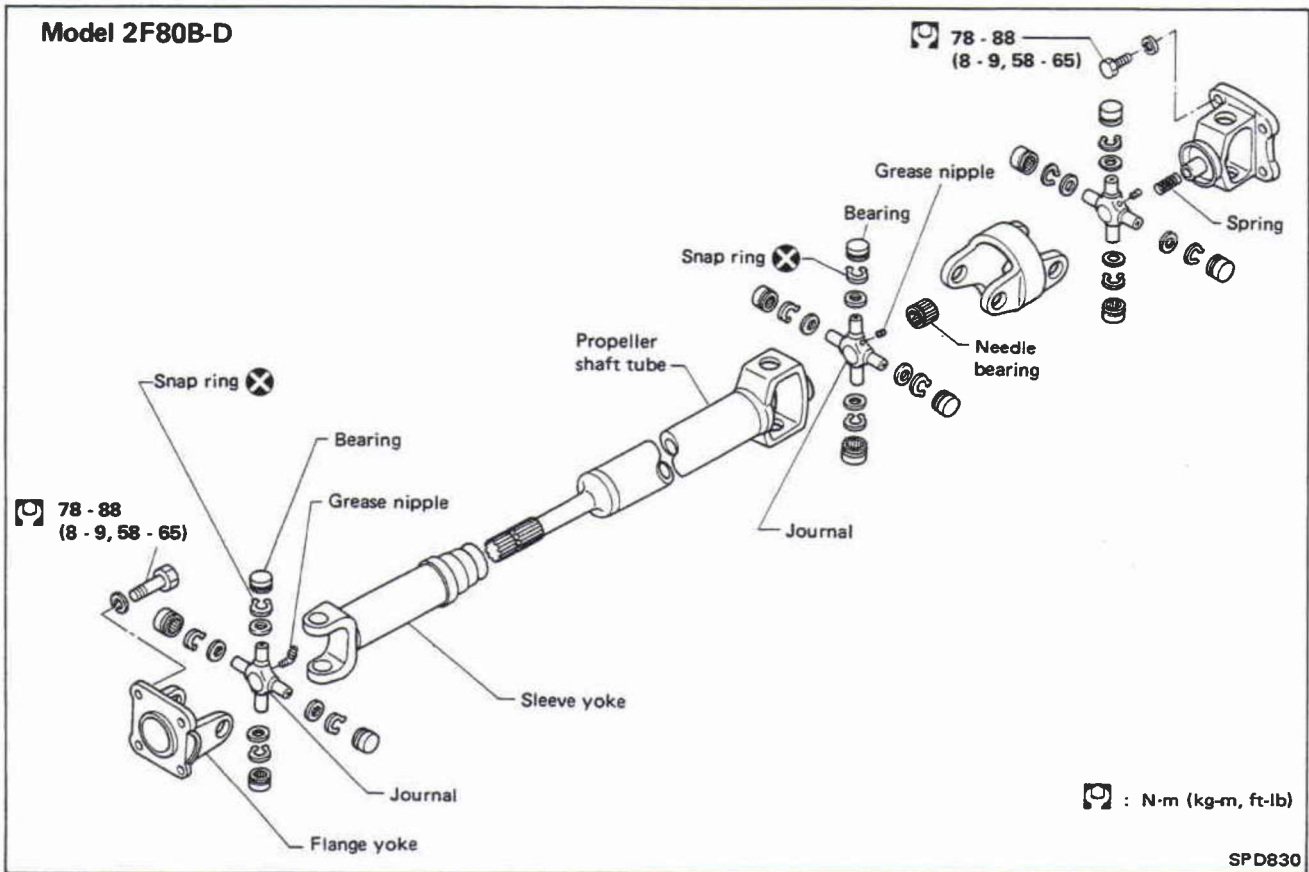
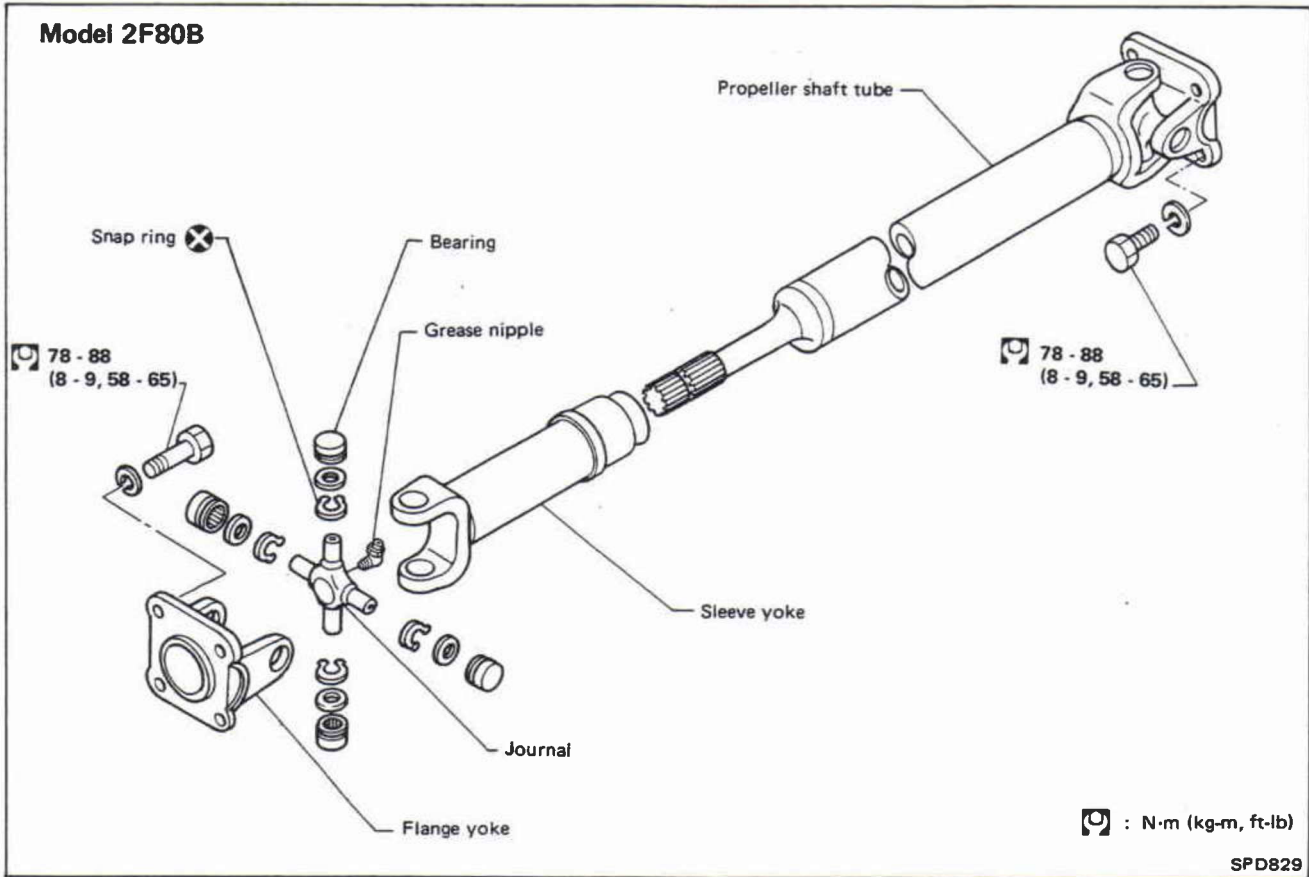

PROPELLER SHAFT

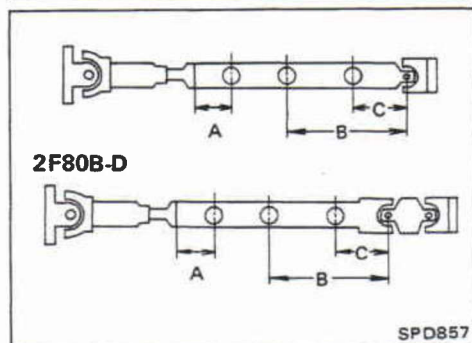
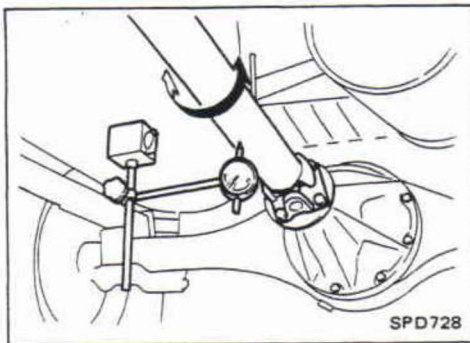
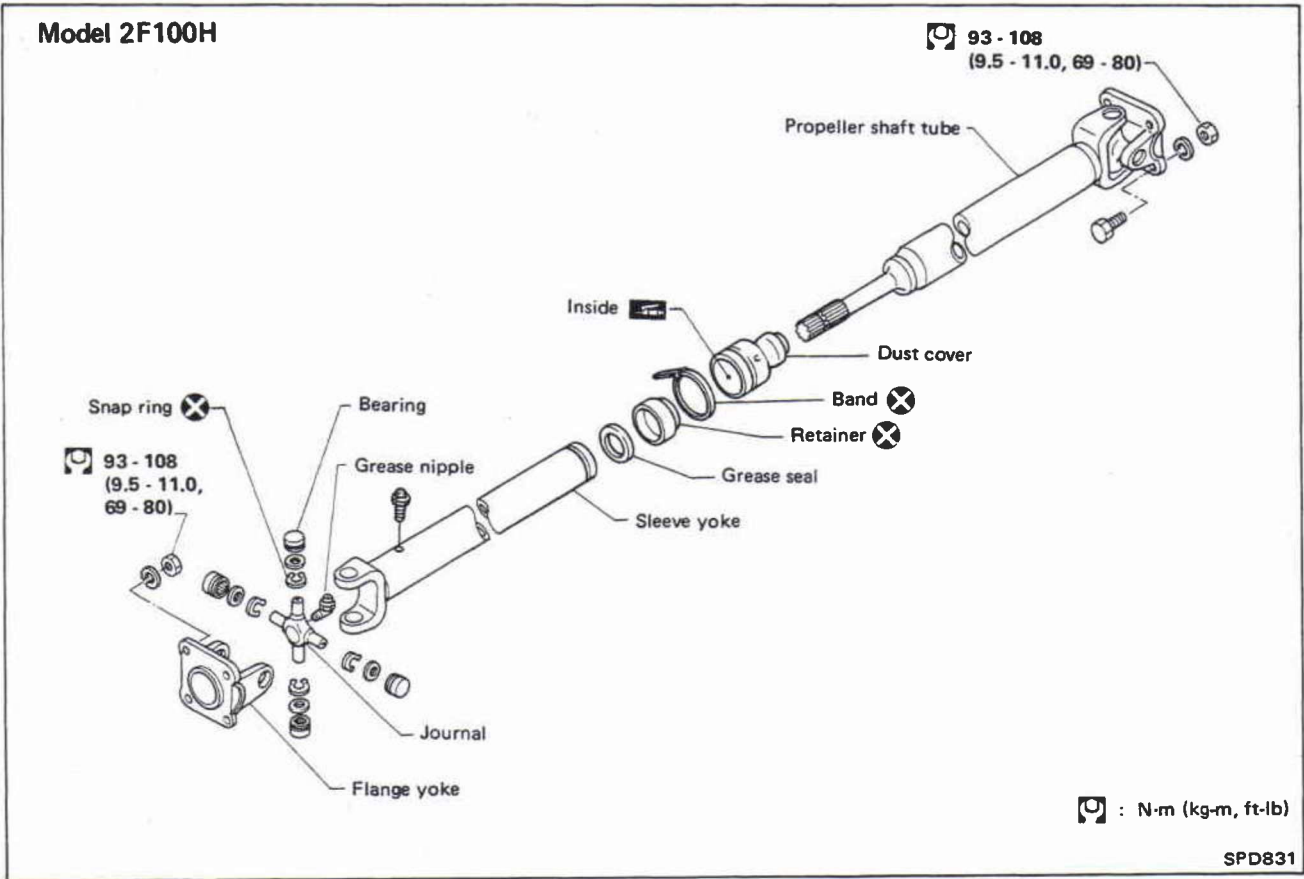

On-vehicle Service

PROPELLER SHAFT VIBRATION

If vibration is present at high speed, inspect propeller shaft runout first.

1. Raise front and rear wheels.
2. Measure propeller shaft runout at several points by rotating final drive companion flange with hands.

Runout limit: 0.6 mm (0.024 in)

Unit: mm (in)

Model	2F80B	2F80B-D	Vehicle		
			Pickup	Wagon	Hardtop
Distance	2F100H				
A	140 (5.51)	70 (2.76)	70 (2.76)	70 (2.76)	—
B	314 (12.36)	455 (17.91)	372.5 (14.67)	367.5 (14.47)	85.0 (3.346)
C	180 (7.09)	170 (6.69)	200 (7.87)	240 (9.45)	—

PROPELLER SHAFT

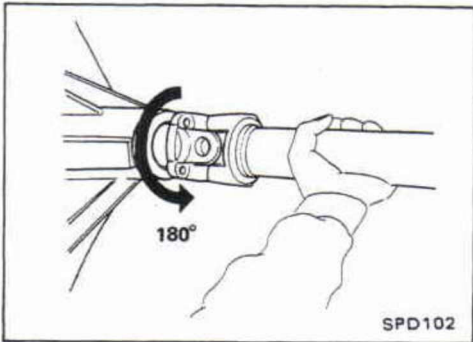

On-vehicle Service (Cont'd)

3. If runout exceeds specifications, disconnect propeller shaft at final drive companion flange; then rotate companion flange 180 degrees and reconnect propeller shaft.
4. Check runout again. If runout still exceeds specifications, replace propeller shaft assembly.
5. Perform road tests.

APPEARANCE CHECKING

- Inspect propeller shaft tube surface for dents or cracks. If damaged, replace propeller shaft assembly.

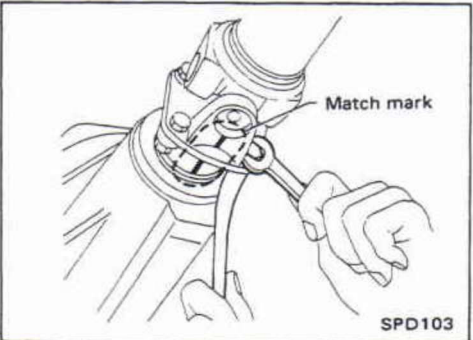

Removal and Installation

- Put match marks on flanges and separate propeller shaft from final drive.

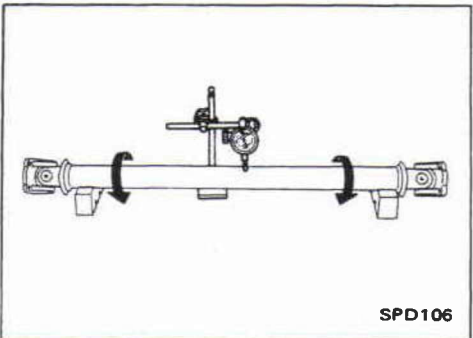

Inspection

- Inspect propeller shaft runout. If runout exceeds specifications, replace propeller shaft assembly.
Runout limit: 0.6 mm (0.024 in)

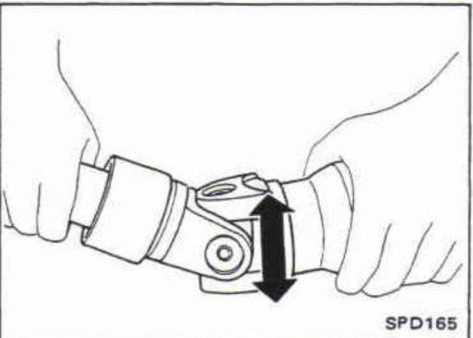

- Inspect journal axial play. If the play exceeds specifications, replace propeller shaft assembly.

Journal axial play:
0.02 mm (0.0008 in) or less

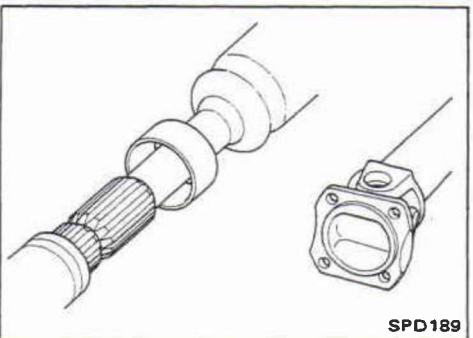

- Check flange yoke and sleeve yoke for damage or wear. Replace if necessary.

PROPELLER SHAFT

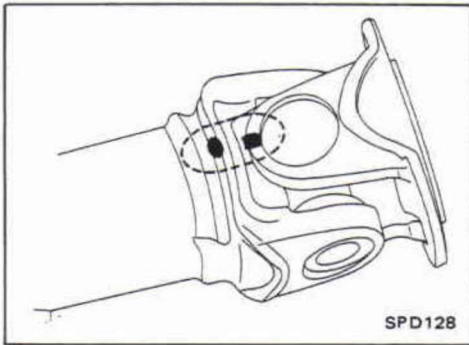

Disassembly JOURNAL

1. Put match marks on shaft and flange or yoke.

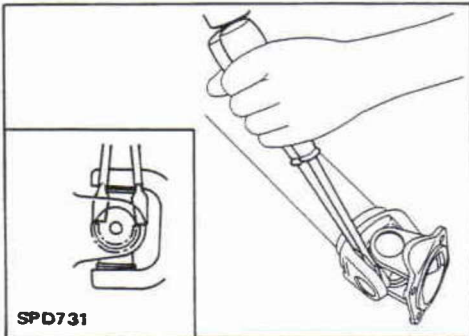

2. Remove snap ring.

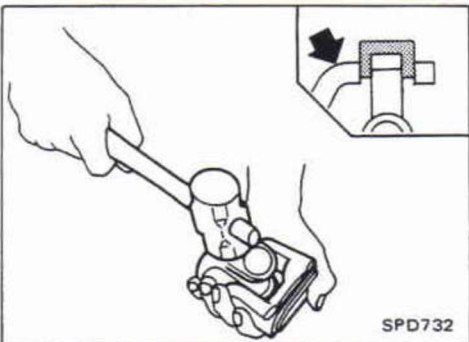

3. Remove pushed out journal bearing by lightly tapping yoke with a hammer, taking care not to damage journal and yoke hole.

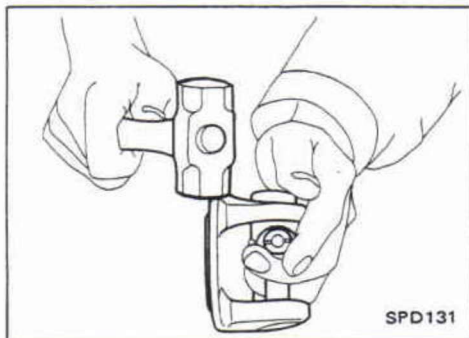

4. Remove bearing at opposite side in above operation. Put marks on disassembled parts so that they can be reinstalled in their original positions from which they were removed.

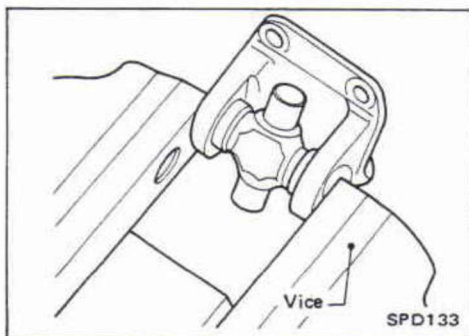

Assembly

JOURNAL (80B, 80B-D and 100H)

1. Assemble journal bearing. Apply recommended multi-purpose grease on bearing inner surface.

When assembling, be careful that needle bearing does not fall down.

PROPELLER SHAFT

Assembly (Cont'd)

2. Select snap ring that will provide specified play in axial direction of journal, and install them. (Refer to S.D.S.)

Select snap rings with a difference in thickness at both sides within 0.06 mm (0.0024 in).

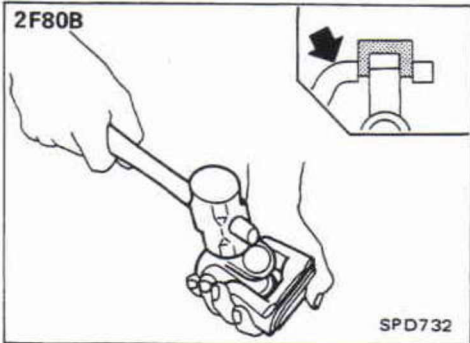
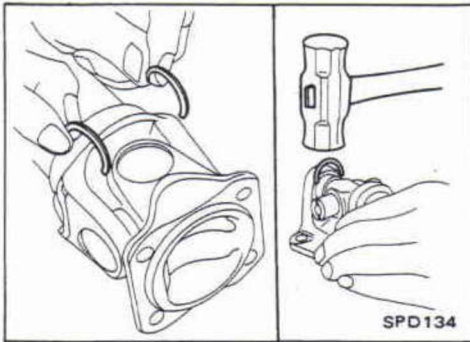

3. Adjust thrust clearance between bearing and snap ring to zero by tapping yoke.

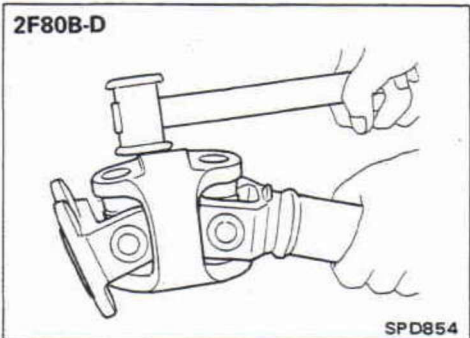

4. Check to see that journal moves smoothly and check for axial play.

Axial play: 0.02 mm (0.0008 in) or less

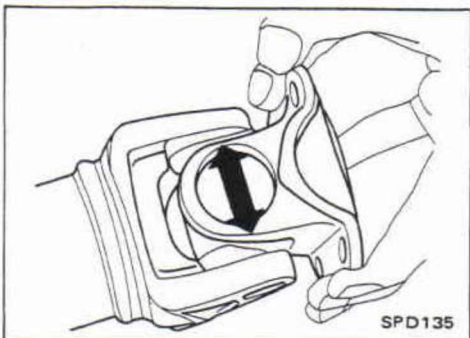

ON-VEHICLE SERVICE (Final Drive)

Front Oil Seal Replacement

1. Remove propeller shaft.
2. Loosen drive pinion nut.

Tool number:

H233B KV40104000

H260 KV38104700

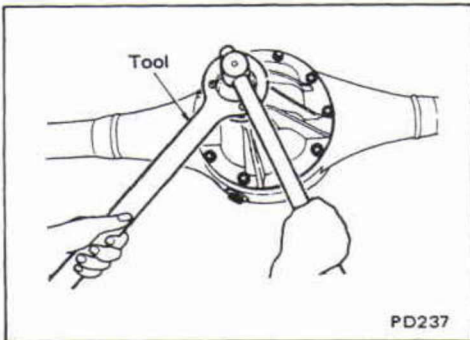

3. Remove companion flange.

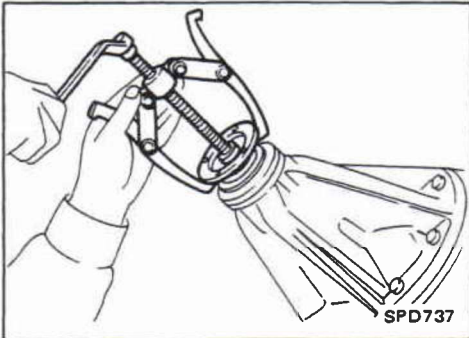

4. Remove front oil seal.

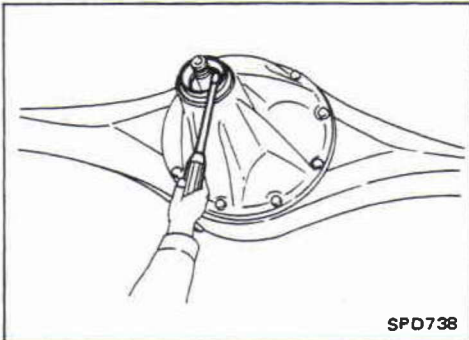

5. Apply multi-purpose grease to sealing lips of oil seal. Press front oil seal into carrier.
6. Install companion flange and drive pinion nut.
7. Install propeller shaft.

Tool number: KV381025S0

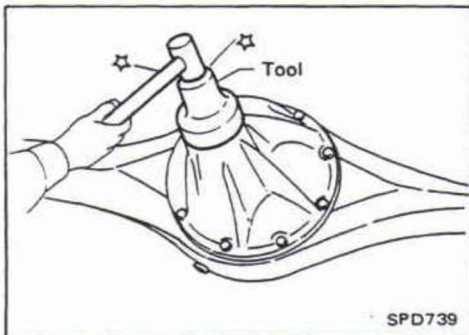

REMOVAL AND INSTALLATION

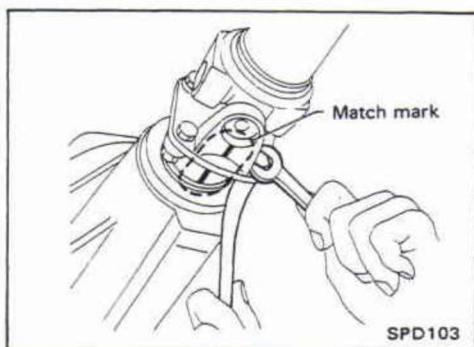

Removal

- Remove propeller shaft.
- Remove axle shaft.
Refer to RA section.

CAUTION:

- Be careful not to damage spline, sleeve yoke and front oil seal when removing propeller shaft.

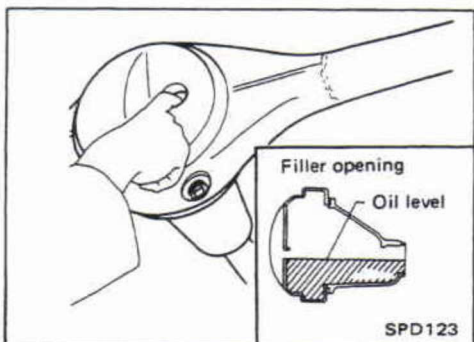

Installation

- Fill final drive with recommended gear oil.

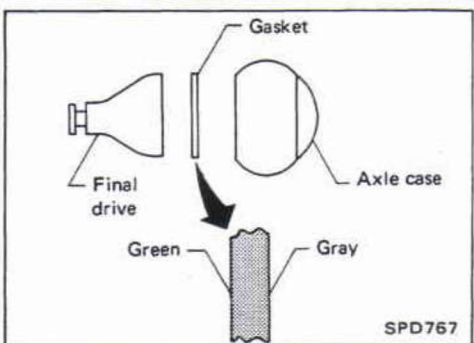

- Pay attention to the direction of gasket (H233B only).

FINAL DRIVE

MODEL: H233B & H260

*: Do not interchange these left side parts with right side parts during assembly.

• When replacing tapered roller bearing, use new outer race and inner race as a set.

• Drive pinion preload:

H233B: 0.5 - 1.0 N·m
(5 - 10 kg-cm, 4.3 - 8.7 in-lb)
H260: 1.5 - 1.7 N·m
(15 - 17 kg-cm, 13 - 15 in-lb)

Total preload:

H233B: 1.0 - 2.0 N·m
(10 - 20 kg-cm, 8.7 - 17.4 in-lb)
H260: 1.7 - 2.5 N·m
(17 - 25 kg-cm, 15 - 22 in-lb)

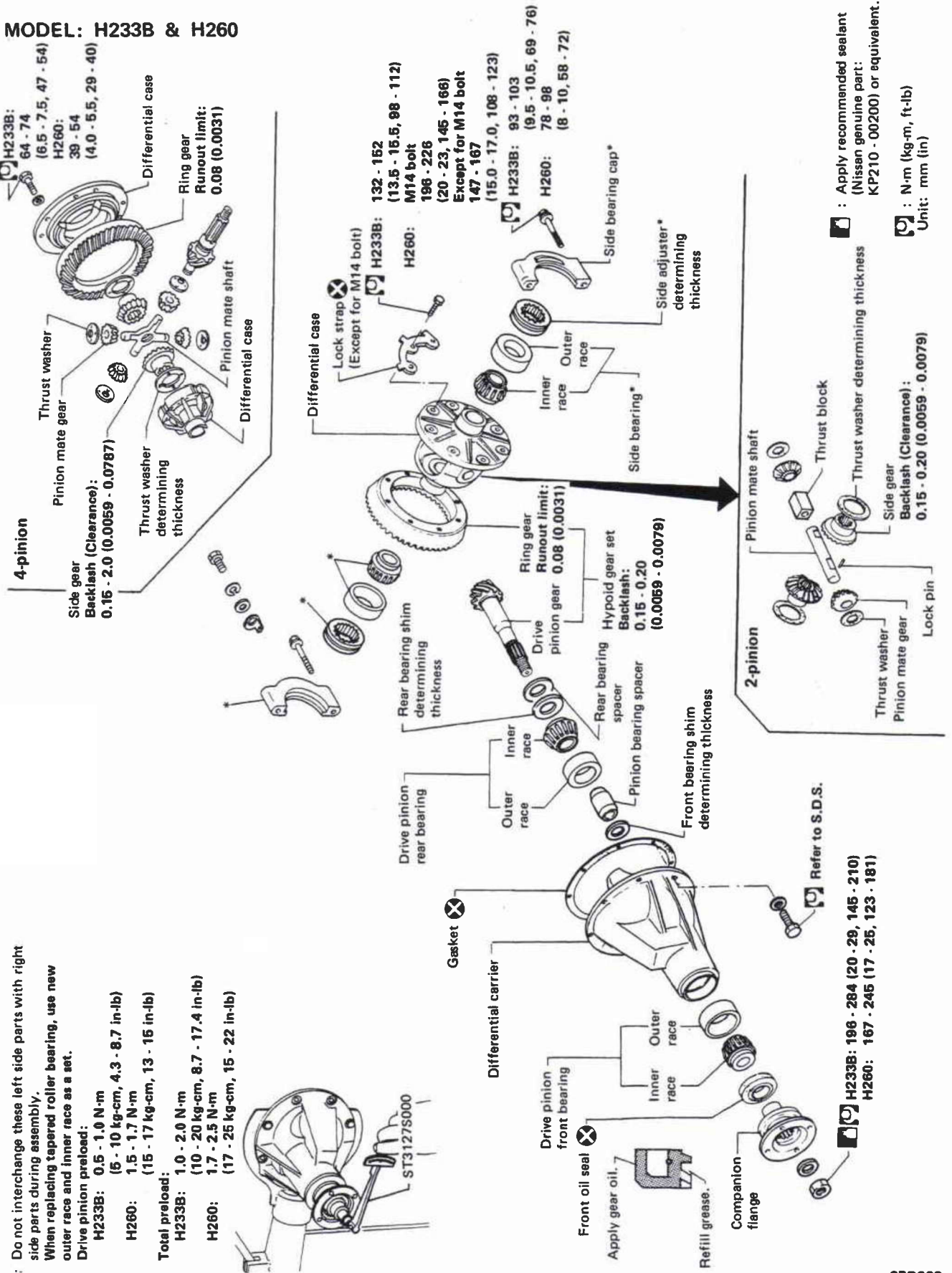
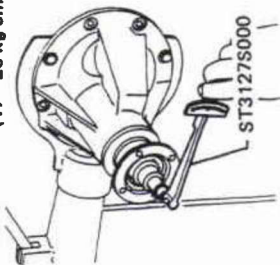

DISASSEMBLY

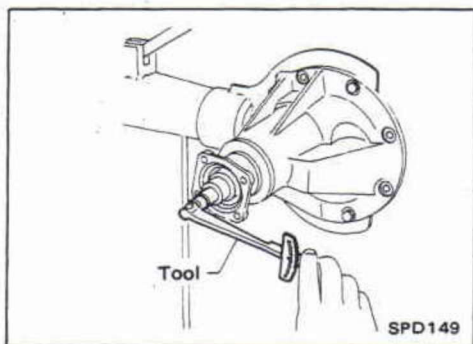

Pre-inspection

Before disassembling final drive, perform the following inspection.

- Total preload
 - 1) Turn drive pinion in both directions several times to set bearing rollers.

- 2) Check total preload with Tool.

Tool number: ST3127S000

Total preload:

H233B

1.8 - 2.5 N·m

(18 - 25 kg-cm, 16 - 22 in-lb)

H260

1.7 - 2.5 N·m

(17 - 25 kg-cm, 15 - 22 in-lb)

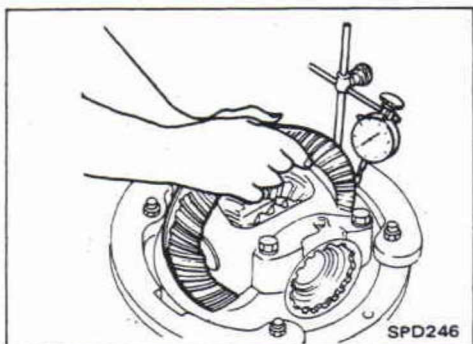

- Ring gear to drive pinion backlash
Check ring gear-to-drive pinion backlash with a dial indicator at several points.

Ring gear-to-drive pinion backlash:

0.15 - 0.20 mm (0.0059 - 0.0079 in)

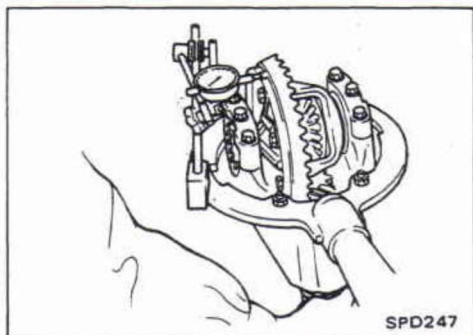

- Ring gear runout
Check runout of ring gear with a dial indicator.

Runout limit:

0.08 mm (0.0031 in)

- Tooth contact
Check tooth contact. (Refer to Adjustment.)

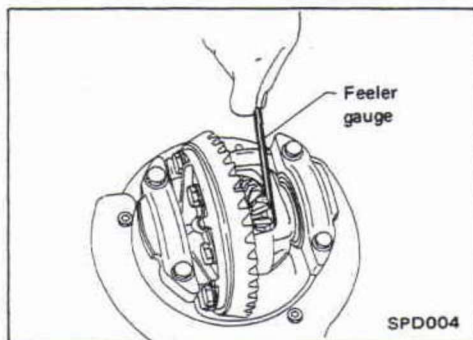

- Side gear to pinion mate gear backlash
Measure clearance between side gear thrust washer and differential case with a feeler gauge.

Clearance between side gear thrust washer and differential case:

0.15 - 0.20 mm (0.0059 - 0.0079 in)

DISASSEMBLY

Differential Carrier

1. Mount differential carrier on Tools.

Tool number:

Ⓐ ST0501S000

Ⓑ H233B: ST06340000

H260: ST06350000

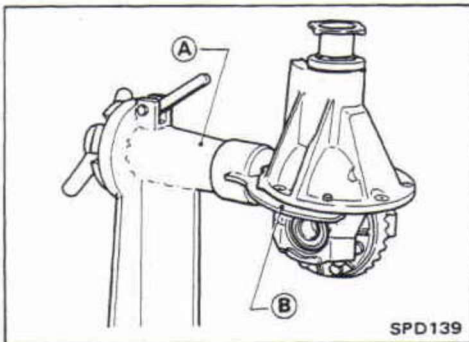

2. Paint or punch match marks on one side of the side bearing cap so it can be properly reinstalled.

Bearing caps are line-bored during manufacture. Replace them in their proper positions.

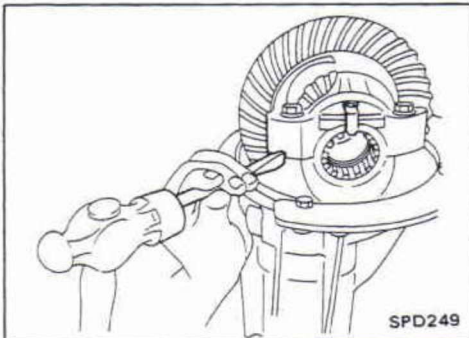

3. Remove side lock fingers and side bearing caps.

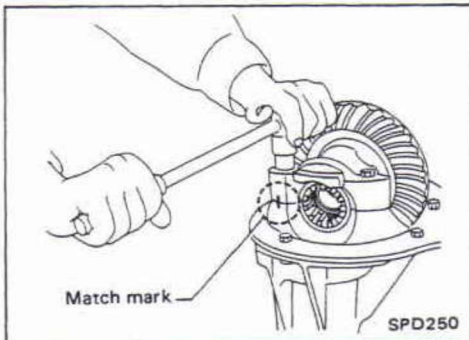

4. Remove side bearing adjuster with Tool.

Tool number: ST32580000

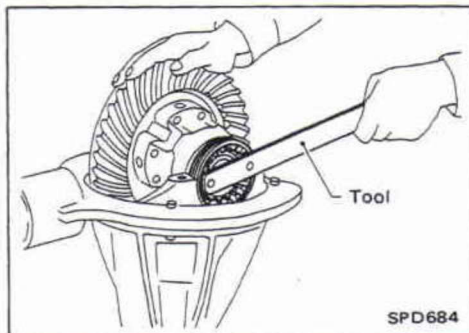

5. Remove differential case assembly with a pry bar.

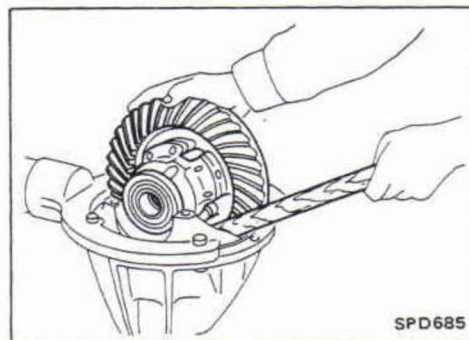

DISASSEMBLY

Differential Carrier (Cont'd)

Be careful to keep the side bearing outer races together with their respective inner races — do not mix them up.

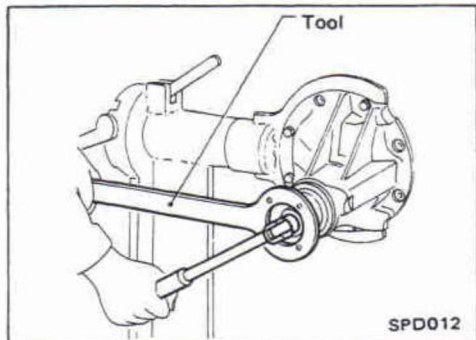
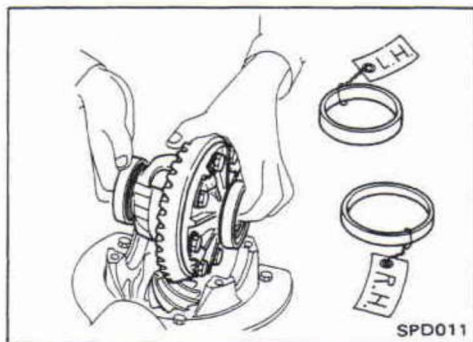

6. Loosen drive pinion nut with Tool.
Tool number: KV38104700

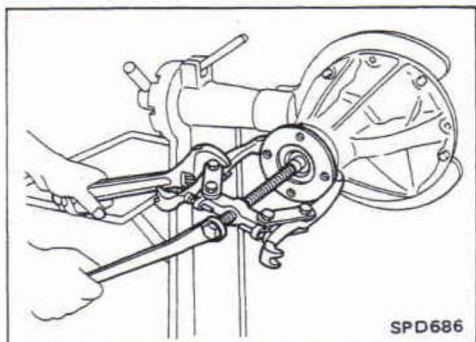

7. Remove companion flange with puller.

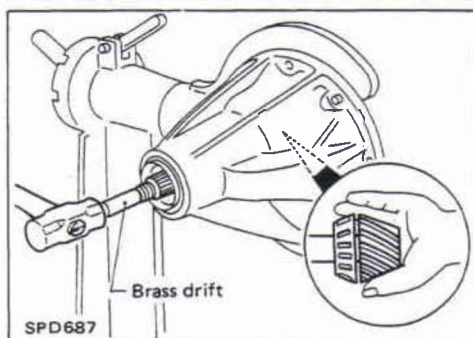

8. Take out drive pinion together with pinion rear bearing inner races, pinion bearing spacer and pinion bearing adjusting shim with soft hammer.

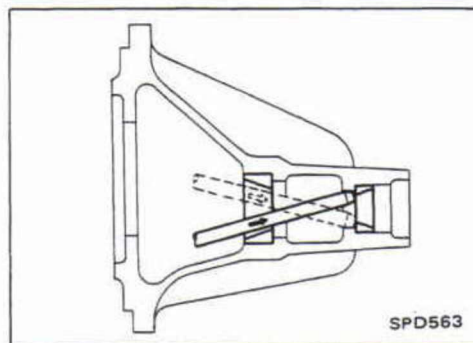

9. Remove front oil seal and pinion front bearing inner races.
10. Remove pinion front and rear bearing outer races with a brass drift.

DISASSEMBLY

Differential Carrier (Cont'd)

11. Remove pinion rear bearing inner races and drive pinion height adjusting washer with press and Tool.

Tool number: ST30031000

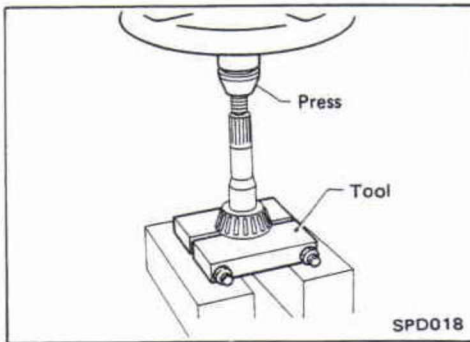

Differential Case

1. Remove side bearing inner races.

To prevent damage to bearing, engage puller jaws in groove.

Tool number:

H233B: (A) ST33051001

(B) ST02371000

H260: (A) ST33051001

(B) ST02371000

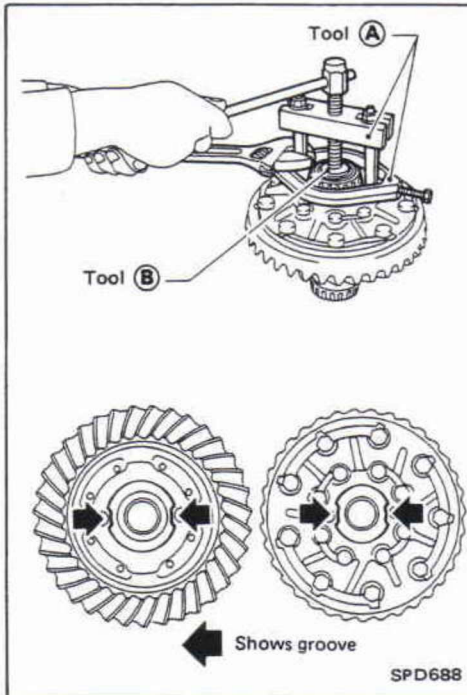

Be careful not to confuse left and right hand parts.

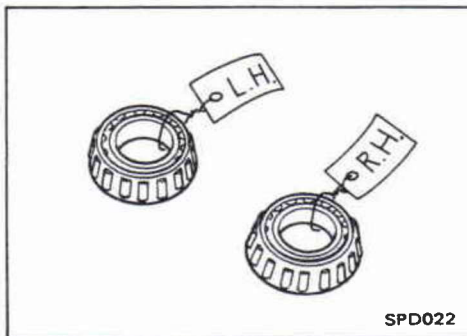

2. Spread out lock straps and loosen ring gear bolts in a criss-cross fashion.

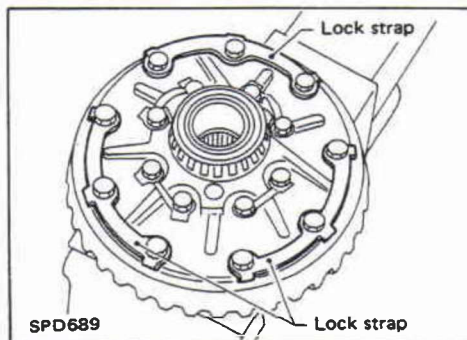

DISASSEMBLY

Differential Case (Cont'd)

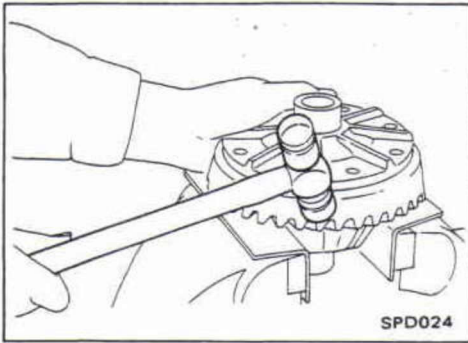

3. Tap ring gear off differential case with a soft hammer.
Tap evenly all around to keep ring gear from binding.

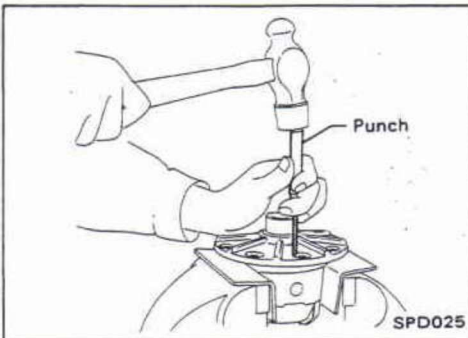

4. Drive out pinion mate shaft lock pin, with Tool from ring gear side (2-pinion type differential case).
Lock pin is calked at pin hole mouth on differential case.

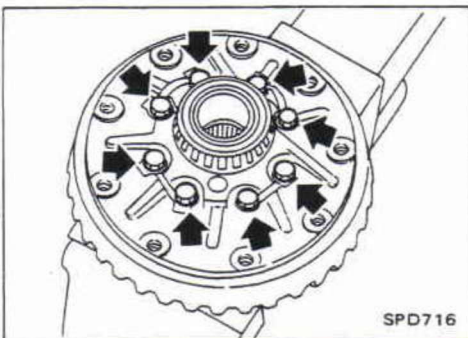

5. Separate differential case L.H. and R.H. (4-pinion type differential case).
Put match marks on both differential case L.H. and R.H. sides prior to separating them.

INSPECTION

Ring Gear and Drive Pinion

Check gear teeth for scoring, cracking or chipping. If any part is damaged, replace ring gear and drive pinion as a set (hypoid gear set).

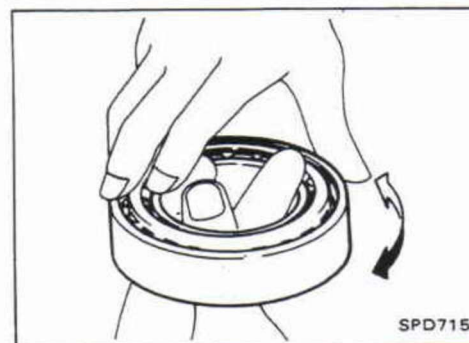
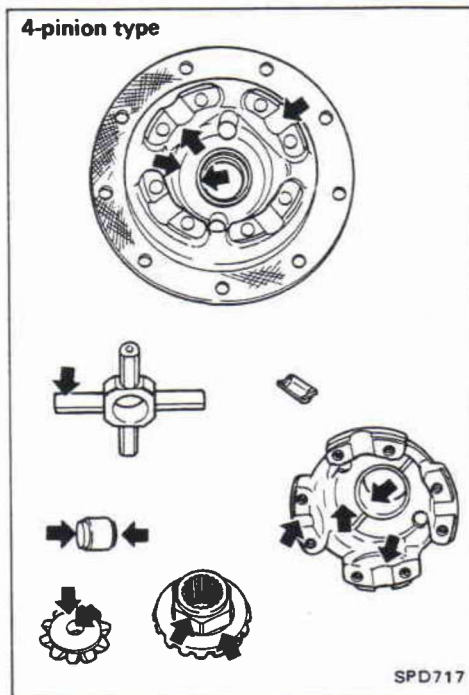
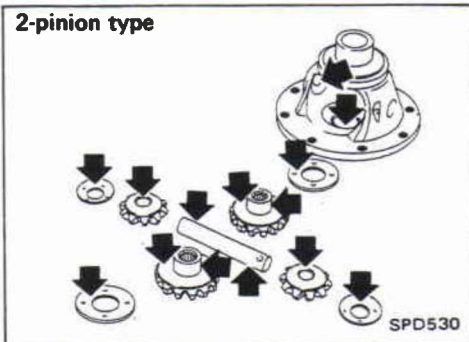

Differential Case Assembly

Check mating surfaces of differential case, side gears, pinion mate gears, pinion mate shaft, thrust block and thrust washers.

Bearing

1. Thoroughly clean bearing.
2. Check bearings for wear, scratches, pitting or flaking. Check tapered roller bearing for smooth rotation. If damaged, replace outer race and inner race as a set.

ADJUSTMENT

For quiet and reliable final drive operation, the following five adjustments must be made correctly:

1. Side bearing preload. (Refer to ASSEMBLY.)
2. Pinion gear height.
3. Pinion bearing preload.
4. Ring gear-to-pinion backlash. (Refer to ASSEMBLY.)
5. Ring and pinion gear tooth contact pattern.

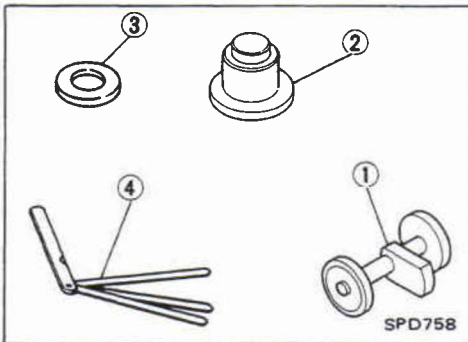

Drive Pinion Height

1. First prepare Tools for pinion height adjustment.

- H233B: ① Height gauge (ST31251000)
 ② Dummy shaft (ST31181001)
 ③ Spacer [thickness: 2.50 mm (0.0984 in)]
 ④ Feeler gauge
- H260: ① Height gauge (ST31130000)
 ② Dummy shaft (ST31241000)
 ④ Feeler gauge

2. To simplify the job, make a chart, like the one below, to organize your calculations.

LETTERS	HUNDREDTHS OF A MILLIMETER
H: Head number	
D': Figure marked on dummy shaft	
S: Figure marked on height gauge	
N: Measuring clearance	

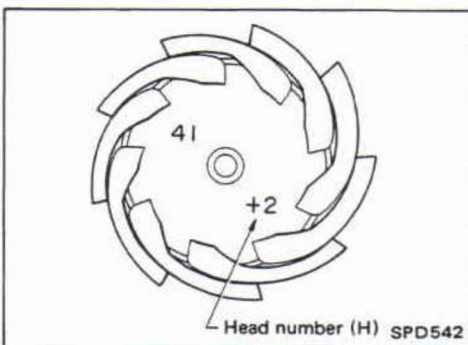

3. Write the following numbers down the chart.

H: Head number

D': Figure marked on dummy shaft.

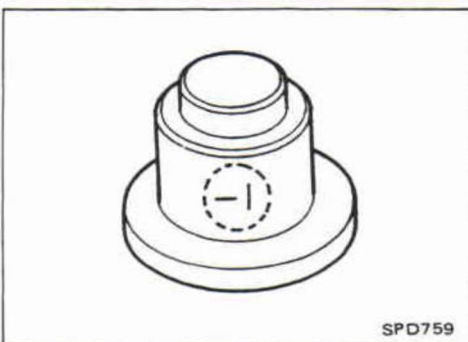

ADJUSTMENT

Drive Pinion Height (Cont'd)

S: Figure marked on height gauge.

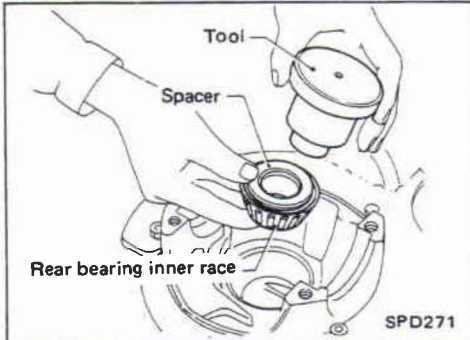
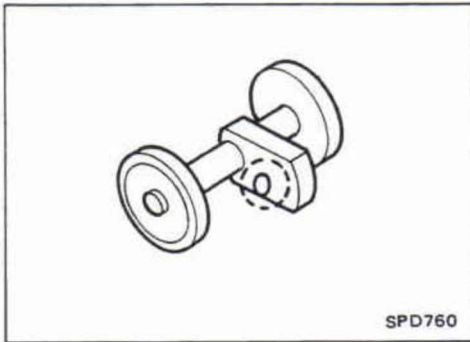

4. Place pinion rear bearing inner race and Tools on gear carrier.

Tool number:

H233B: ST31181001

H260: ST31241000

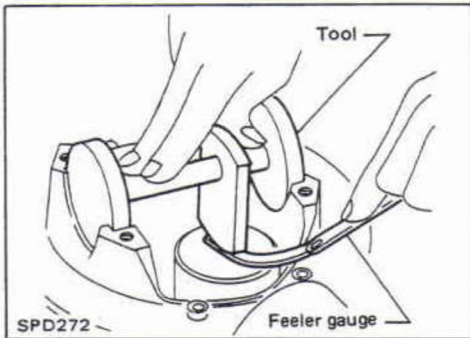

5. Attach Tool (Height gauge) to gear carrier, and measure the clearance between the height gauge and the dummy shaft face.

Tool number:

H233B: ST31251000

H260: ST31130000

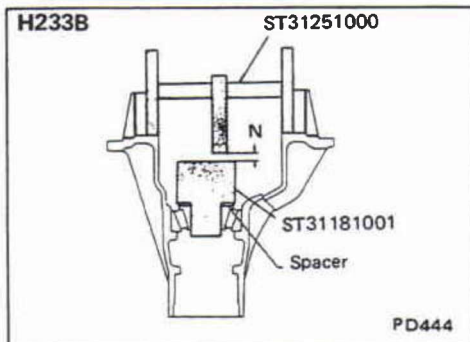

6. Substitute these values into the equation to calculate the thickness of the washer.

If values signifying H, D' and S are not given, regard them as zero and calculate.

H233B:

T (Thickness of washer)

$$= N - [(H - D' - S) \times 0.01] + 3.05$$

H260:

T (Thickness of washer)

$$= N - [(H - D' - S) \times 0.01] + 2.55$$

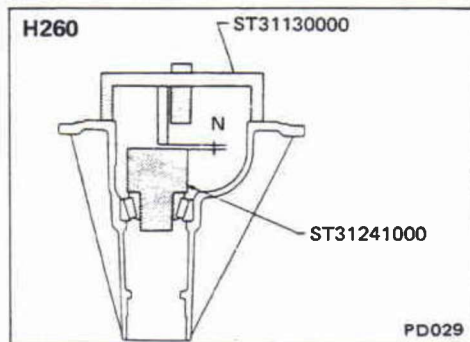

ADJUSTMENT

Tooth Contact

Gear tooth contact pattern check is necessary to verify correct relationship between ring gear and drive pinion.

Hypoid gear sets which are not positioned properly may be noisy, or have short life, or both. Low noise and a long life can be assured with a pattern check.

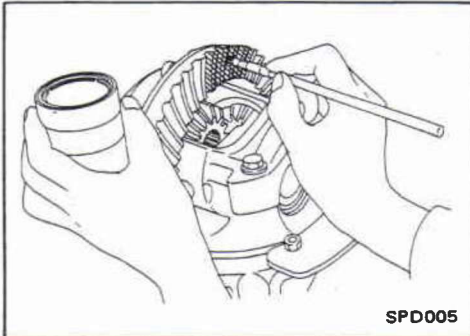

1. Thoroughly clean ring gear and drive pinion teeth.
2. Sparingly apply a mixture of powdered ferric oxide and oil or equivalent to 3 or 4 teeth of ring gear drive side.

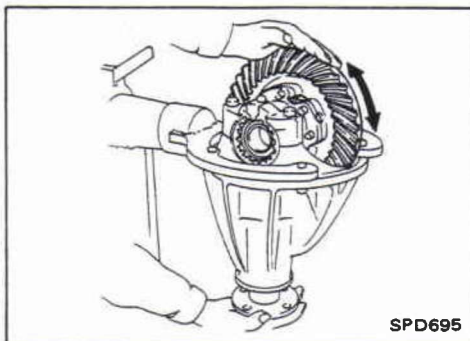

3. Hold companion flange steady and turn the ring gear in both directions.

Usually the pattern will be correct if you have calculated the shims correctly and the backlash is correct. However, in rare cases you may have to use trial-and-error processes until you get a good tooth contact pattern. The tooth pattern is the best indication of how well a differential has been set up.

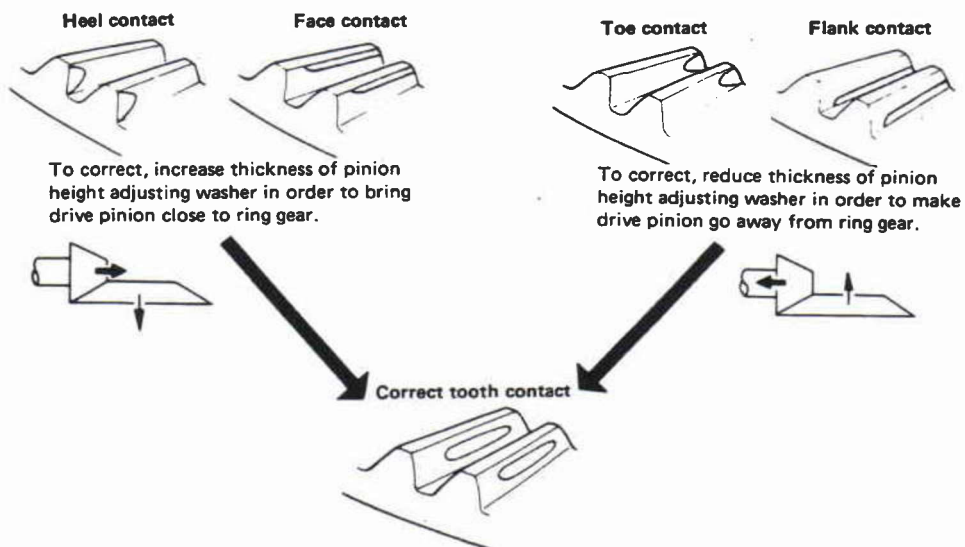

SPD007

ASSEMBLY

Differential Case — 4-pinion type —

1. Measure clearance between side gear thrust washer and differential case.

Clearance between side gear thrust washer and differential case (A - B):

0.15 - 0.20 mm (0.0059 - 0.0079 in)

The clearance can be adjusted with side gear thrust washer. Refer to S.D.S.

2. Apply oil to gear tooth surfaces and thrust surfaces and check that they turn properly.

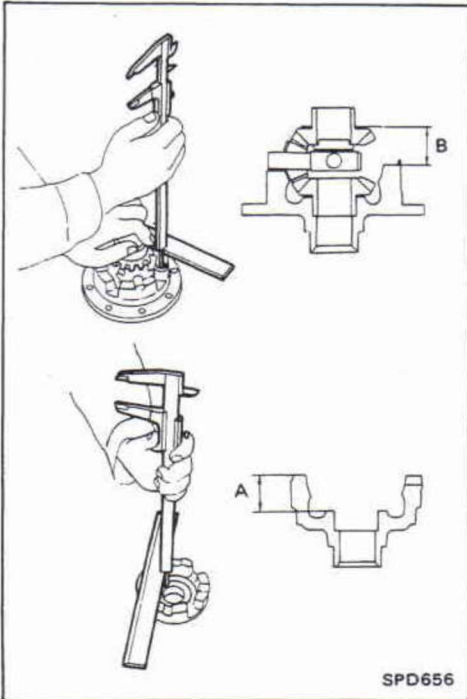

3. Install differential case L.H. and R.H.

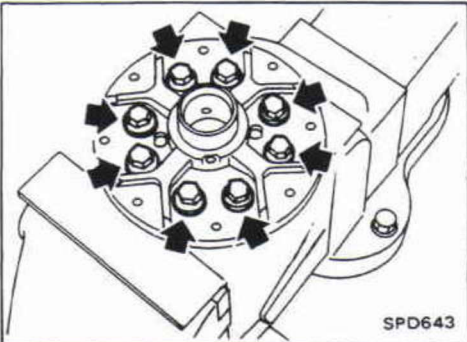

4. Place differential case on ring gear.
5. Apply locking sealer to ring gear bolts, and install them. Tighten bolts in a criss-cross fashion, lightly tapping bolt head with a hammer.

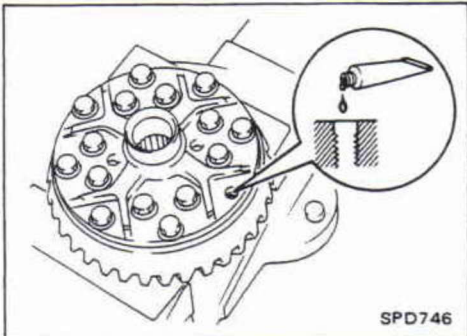

6. Press-fit side bearing inner races on differential case with Tool.

Tool number:

- Ⓐ H233B: ST33190000
H260: Drift
- Ⓑ H233B: ST02371000
H260: Drift

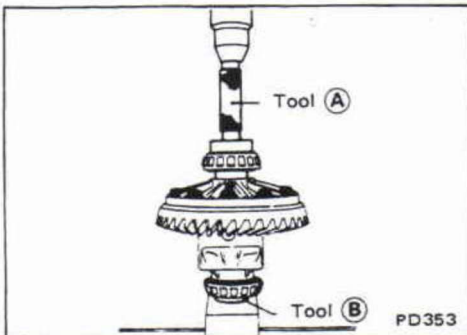

ASSEMBLY

Differential Case — 2-pinion type —

1. Install side gears, pinion mate gears, thrust washers and thrust block into differential case.

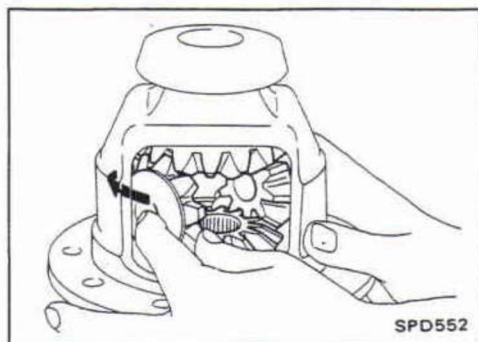

2. Fit pinion mate shaft to differential case so that it meets lock pin holes.

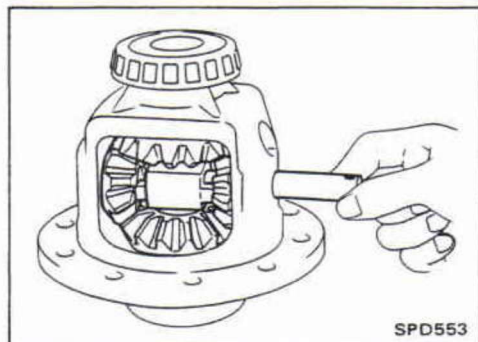

3. Adjust clearance between rear face of side gear and thrust washer by selecting side gear thrust washer. Refer to S.D.S.
Clearance between side gear thrust washer and differential case:
0.15 - 0.20 mm (0.0059 - 0.0079 in)

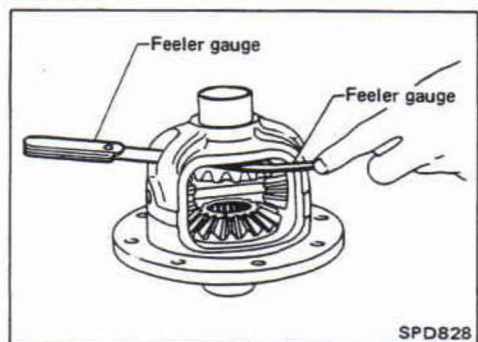

4. Install pinion mate shaft lock pin with a punch.
Make sure lock pin is flush with case.

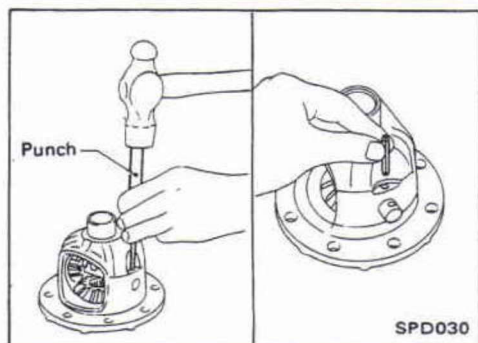

5. Apply oil to gear tooth surfaces and thrust surfaces and check that they turn properly.

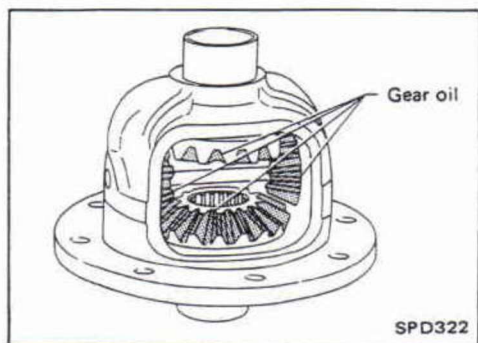

ASSEMBLY

Differential Case — 2-pinion type — (Cont'd)

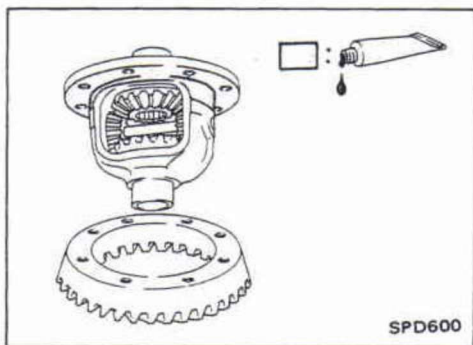

6. Apply locking sealer to contacting surfaces of ring gear and differential case, then place differential case on ring gear.

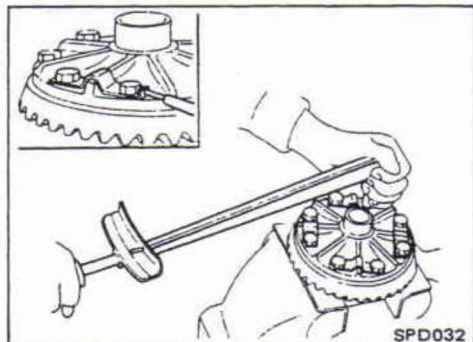

7. Apply locking sealer to ring gear bolts.
8. Install new lock straps and ring gear bolts.
 - Tighten bolts in a criss-cross fashion, lightly tapping bolt head with a hammer.
 - Ⓜ: 78 - 93 N·m
(8.0 - 9.5 kg-m, 58 - 69 ft-lb)
 - Then bend up lock straps to lock the bolts in place.

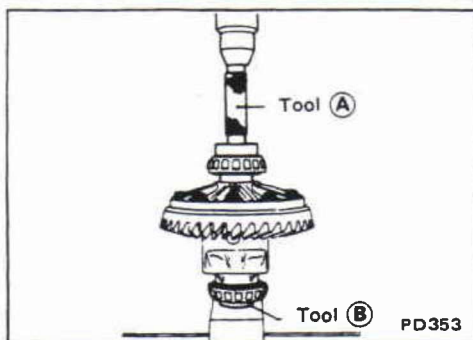

9. Press-fit side bearing inner races on differential case with Tool.

Tool number:

- (A) ST33190000
- (B) ST02371000

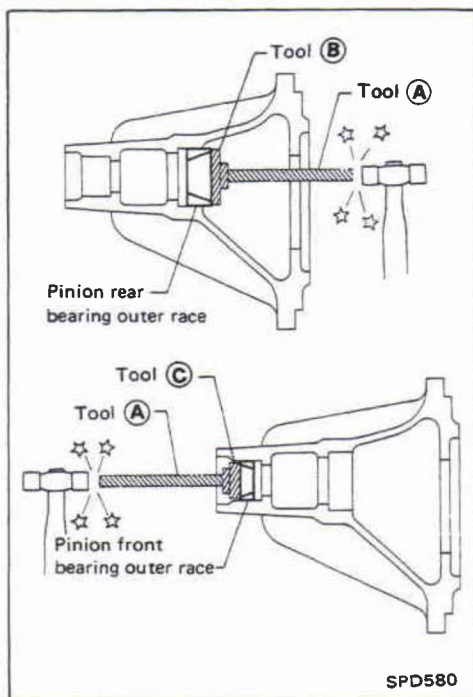

Differential Carrier

1. Press-fit front and rear bearing outer races with Tools.

Tool number:

- (A) ST30611000
- (B) ST30621000 (front differential)
or suitable pipe
- (C) ST30701000 (H233B)
For H260, use suitable pipe.

CAUTION:

Do not damage roller side face.

2. Select pinion bearing adjusting washer and drive pinion bearing spacer, referring to Adjustment.

ASSEMBLY

Differential Carrier (Cont'd)

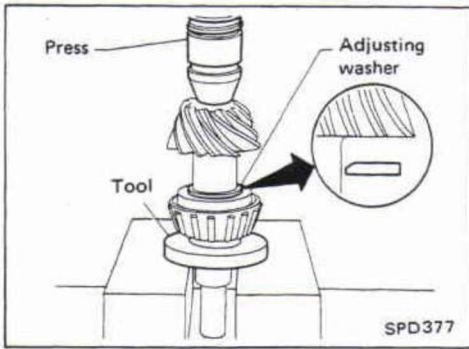

3. Install drive pinion height adjusting washer in drive pinion, and press-fit pinion rear bearing inner race in it, using press and Tool.

Tool number: ST30911000

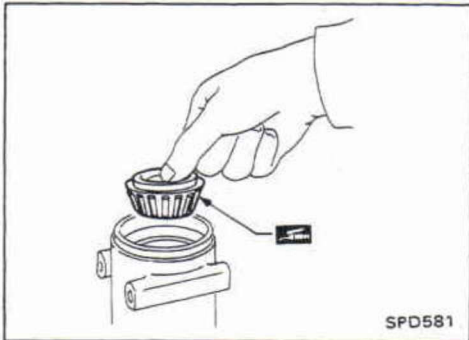

4. Place pinion front bearing inner race in final drive housing.

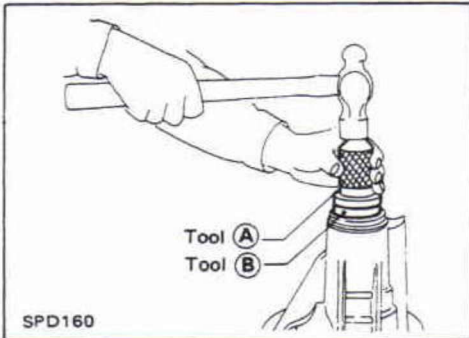

5. Apply multi-purpose grease to cavity at sealing lips of oil seal. Install front oil seal.

Tool number:

(A) ST30720000

(B) KV38102510

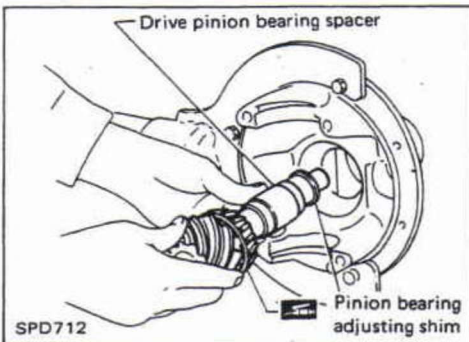

6. Install drive pinion bearing spacer, pinion bearing adjusting shim and drive pinion in gear carrier.

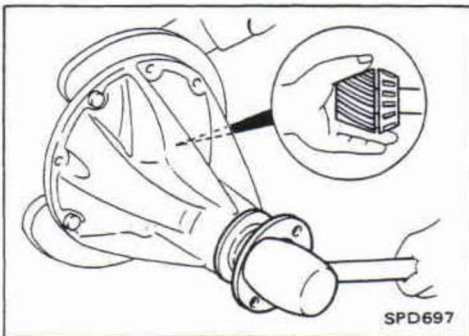

7. Insert companion flange into drive pinion by tapping the companion flange with a soft hammer.

ASSEMBLY

Differential Carrier (Cont'd)

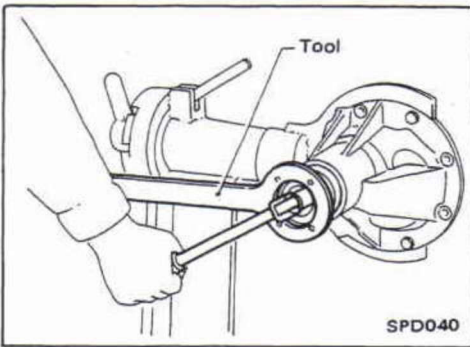

8. Tighten pinion nut to the specified torque.

The threaded portion of drive pinion and pinion nut should be free from oil or grease.

Tool number: KV38104700

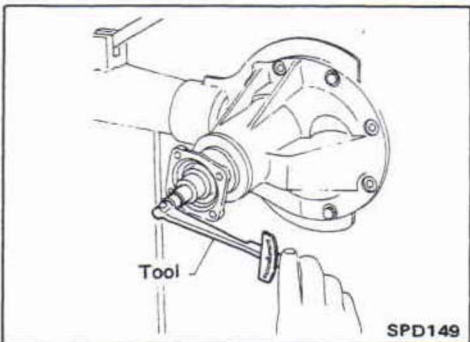

9. Turn drive pinion in both directions several times; and measure pinion bearing preload.

Tool number: ST3127S000

Pinion bearing preload:

H233B

1.3 - 1.6 N·m

(13 - 16 kg-cm, 11 - 14 in-lb)

H260

1.5 - 1.7 N·m

(15 - 17 kg-cm, 13 - 15 in-lb)

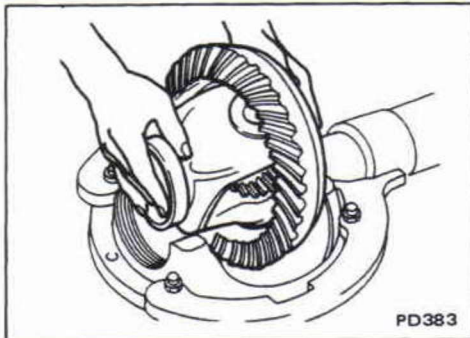

10. Install differential case assembly with side bearing outer races into gear carrier.

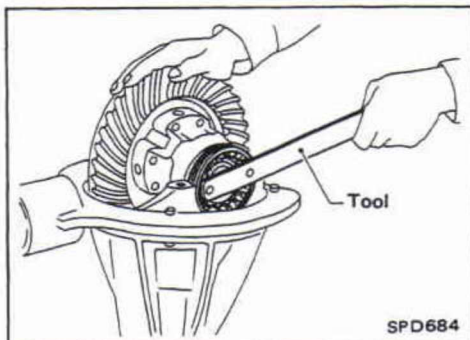

11. Position side bearing adjusters on gear carrier with threads properly engaged; screw in adjusters lightly at this stage of assembly.

Tool number:

H233B: ST32580000

H260: ST32530000

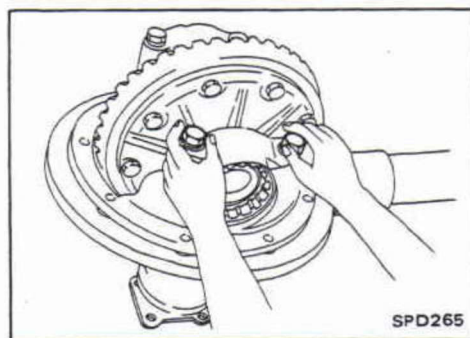

12. Align mark on bearing cap with that on gear carrier and install bearing cap on gear carrier.

- Do not tighten at this point to allow further tightening of side bearing adjusters.

ASSEMBLY

Differential Carrier (Cont'd)

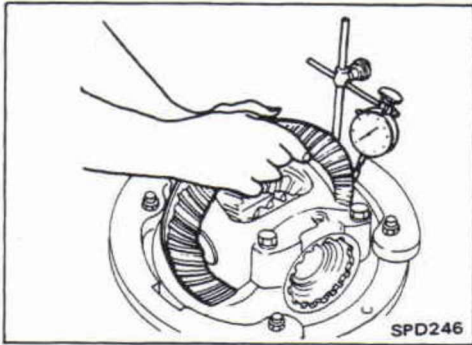

13. Tighten both right and left side bearing adjusters alternately and measure ring gear backlash and total preload at the same time. Adjust right and left side bearing adjusters by tightening them alternately so that proper ring gear backlash and total preload can be obtained.

Ring gear-to-drive pinion backlash:
0.15 - 0.20 mm (0.0059 - 0.0079 in)

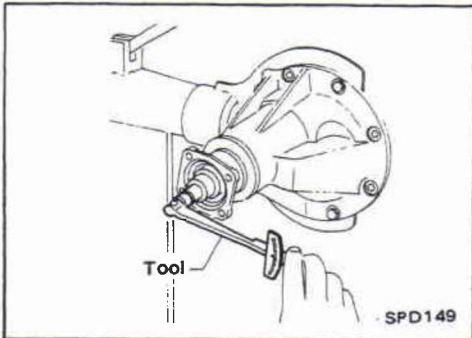

- When checking preload, turn drive pinion in both directions several times to set bearing rollers.

Tool number: ST3127S000

Total preload:

H233B

1.8 - 2.5 N·m

(18 - 25 kg-cm, 16 - 22 in-lb)

H260

1.7 - 2.5 N·m

(17 - 25 kg-cm, 15 - 22 in-lb)

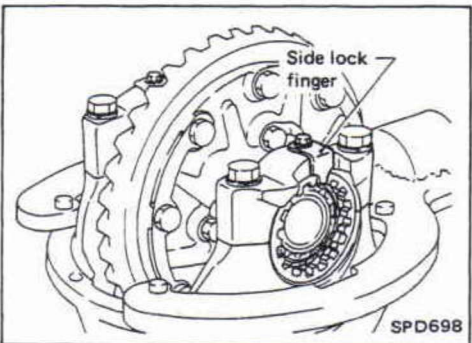

14. Tighten side bearing cap bolts.

15. Install side lock finger in place to prevent rotation during operation.

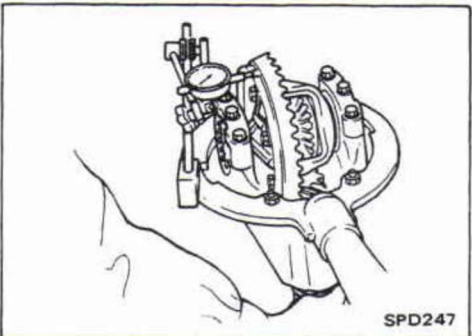

16. Check runout of ring gear with a dial indicator.

Runout limit: 0.08 mm (0.0031 in)

- If backlash varies excessively in different places, foreign matter may be caught between the ring gear and the differential case.
- If the backlash varies greatly when the ring gear runout is within a specified range, replace the hypoid gear set or differential case.

17. Check tooth contact. (Refer to Adjustment.)

LIMITED SLIP DIFFERENTIAL (For H260)

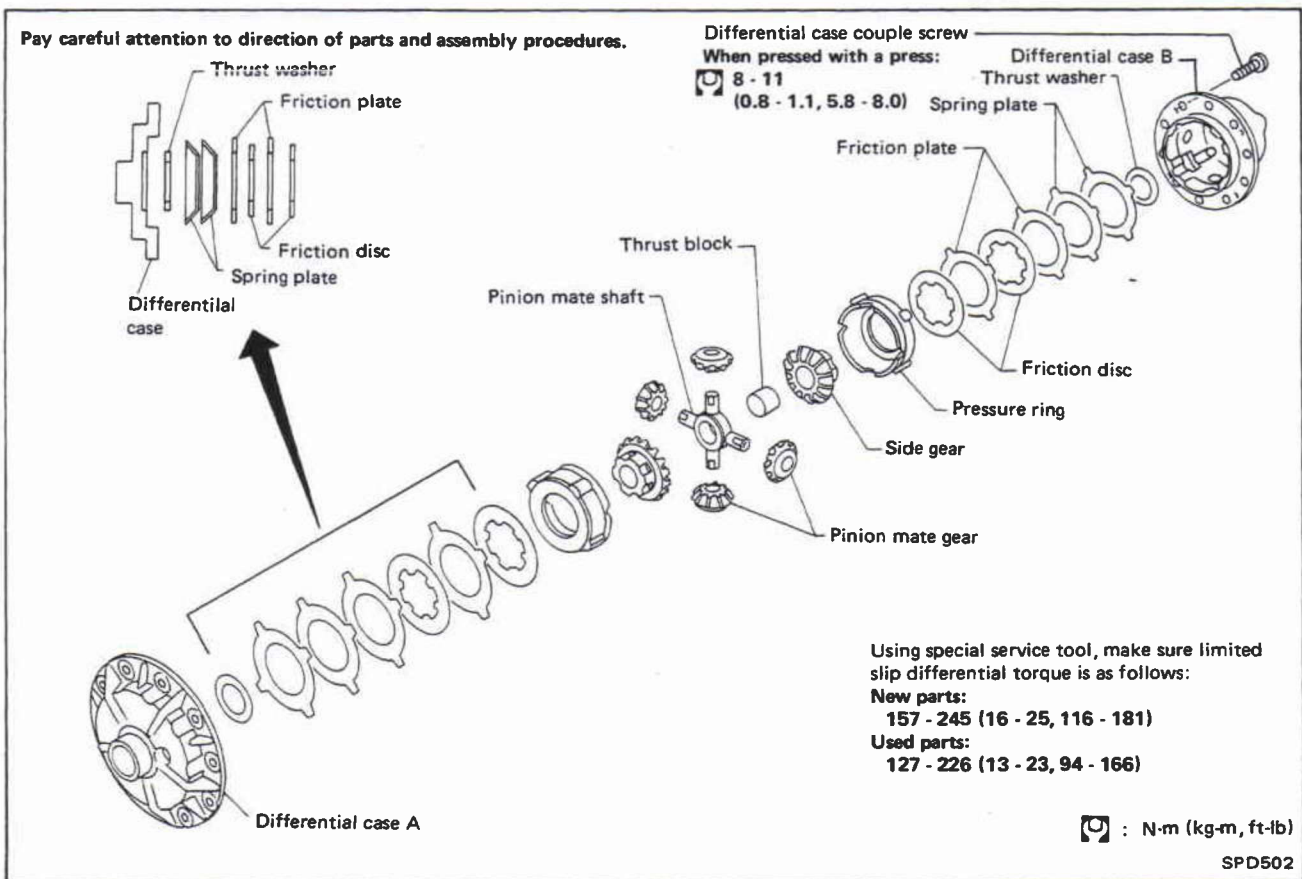

CAUTION:

Do not run engine when one wheel (rear) is off the ground.

Preparation for Disassembly

CHECKING DIFFERENTIAL TORQUE

Measure differential torque and ensure that it is in the specified range.

Differential torque:

New parts

157 - 245 N·m (16 - 25 kg·m, 116 - 181 ft·lb)

Used parts

127 - 226 N·m (13 - 23 kg·m, 94 - 166 ft·lb)

Tool number:

KV38106400 (Except for Middle East)

KV38107100 (Middle East)

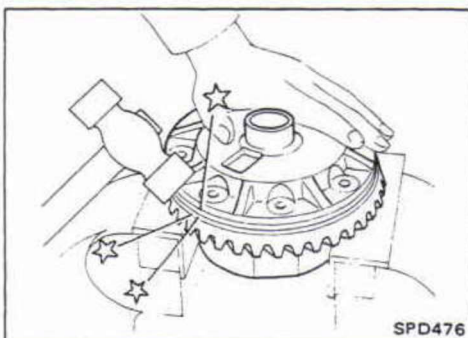
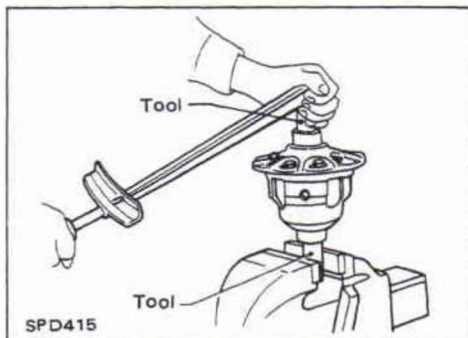

Disassembly

1. Remove side bearing inner race with Tool.
2. Loosen ring gear bolts in a criss-cross fashion.
3. Tap ring gear off gear case using a soft hammer.
Tap evenly all around to keep ring gear from binding.

LIMITED SLIP DIFFERENTIAL (For H260)

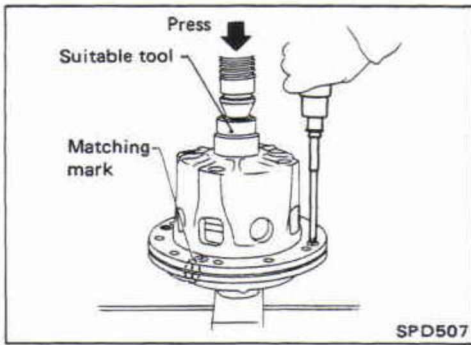

Disassembly (Cont'd)

4. Loosen screws on differential cases A and B using a press.
5. Separate differential cases A and B. Draw out component parts (discs and plates, etc.).

Put marks on gears, discs and plates so that they can be reinstalled in their original positions from which they were removed.

Inspection

CONTACT SURFACES

1. Clean the disassembled parts in suitable solvent and blow dry with compressed air.
2. If following surfaces are found with burrs or scratches, smooth with oil stone.
 - ① Differential case A
 - ② Differential case B
 - ③ Pressure ring
 - ④ Thrust washer
 - ⑤ Pinion mate shaft
 - ⑥ Thrust block
 - ⑦ Pinion mate gear
 - ⑧ Side gear

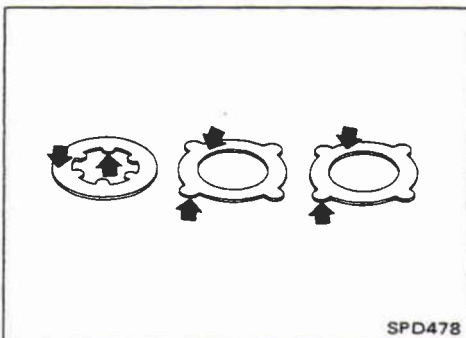
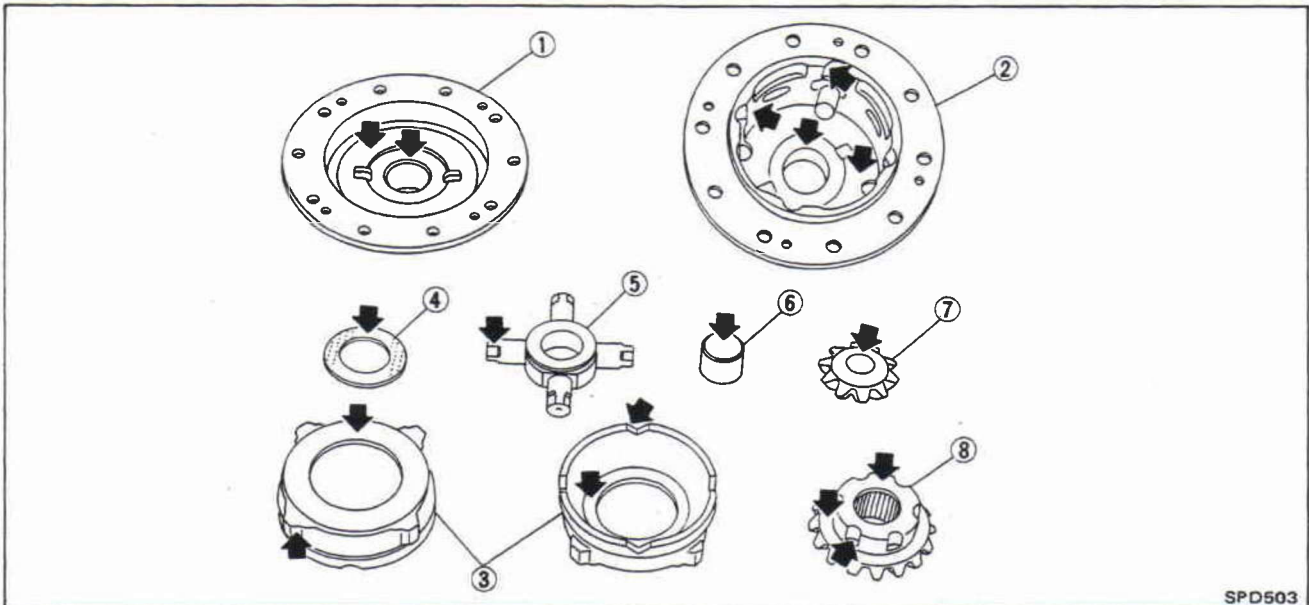

DISC AND PLATE

1. Clean the discs and plates in suitable solvent and blow dry with compressed air.
2. Inspect discs and plates for wear, nicks and burrs.

LIMITED SLIP DIFFERENTIAL (For H260)

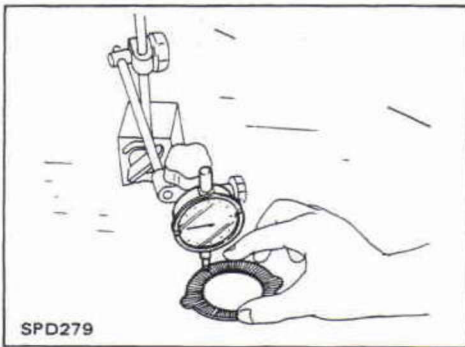

SPD279

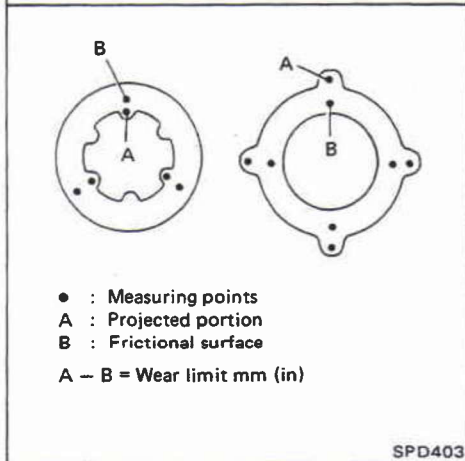
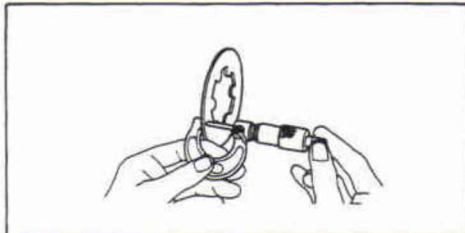

SPD403

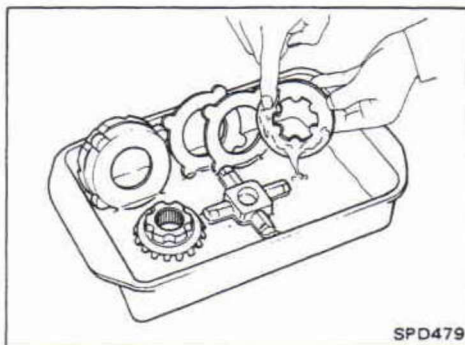

SPD479

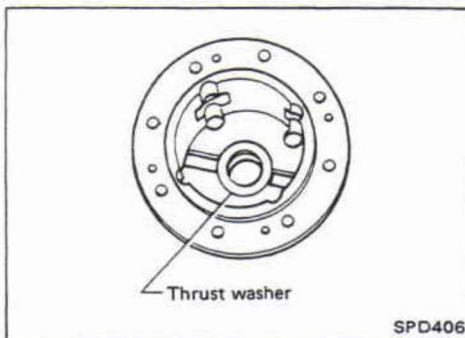

SPD406

Inspection (Cont'd)

3. To test if friction disc or plate is not distorted, place it on a surface plate and rotate it by hand with indicating finger of dial gauge resting against disc or plate surface.

Maximum allowable warpage:

0.08 mm (0.0031 in)

If it exceeds limits, replace with a new plate to eliminate possibility of clutch slippage or sticking.

4. Measure frictional surfaces and projected portions of friction disc, friction plate, spring plate, and determine each part's differences to see if the specified wear limit has been exceeded. If any part has worn beyond the wear limit, replace it with a new one that is the same thickness as the projected portion.

Wear limit:

0.1 mm (0.004 in) or less

Assembly

Assemble differential case in the reverse order of disassembly, observing the following.

1. As an aid to installation, apply sufficient amounts of recommended limited slip differential gear oil (refer to MA section) to the faces of pressure rings, discs and plates to be assembled together.
2. Place differential case B on a level surface, then install thrust washer.

LIMITED SLIP DIFFERENTIAL (For H260)

Assembly (Cont'd)

3. Install spring plates, friction plates and friction discs.
Pay particular attention to the direction of clutch plates and their assembly sequence.

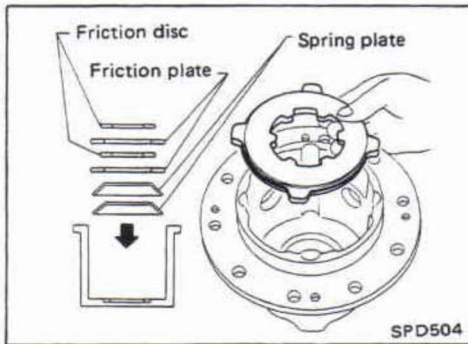

4. Install pressure ring.

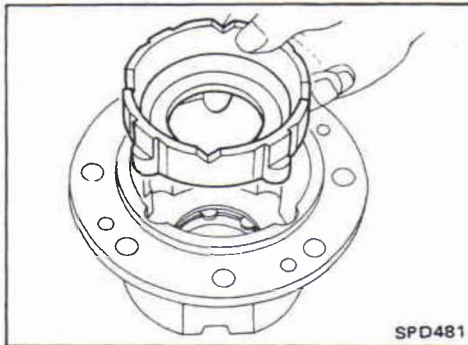

5. Install side gear by inserting projected portion of disc.

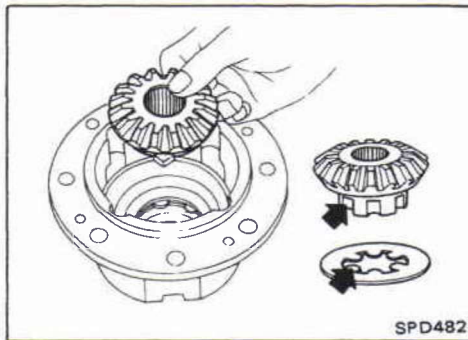

6. Install pinion mate gears and shaft.
Always attach pinion mate shaft to "V" groove in pressure ring with flat surfaces facing up and down.

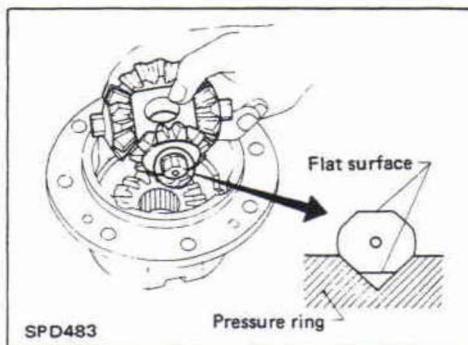

7. Install thrust block.

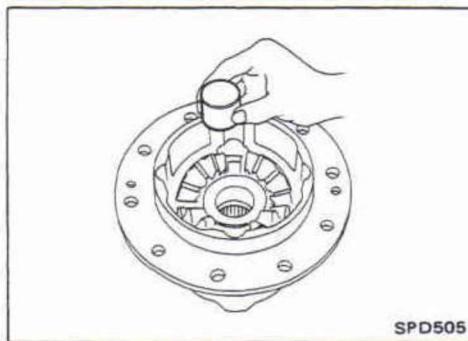

LIMITED SLIP DIFFERENTIAL (For H260)

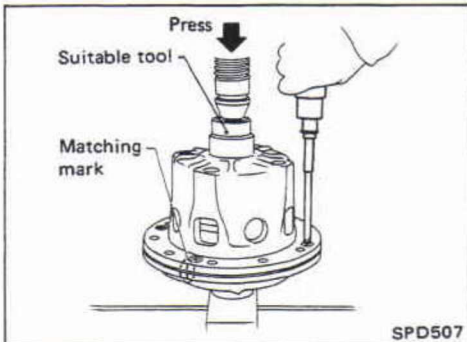
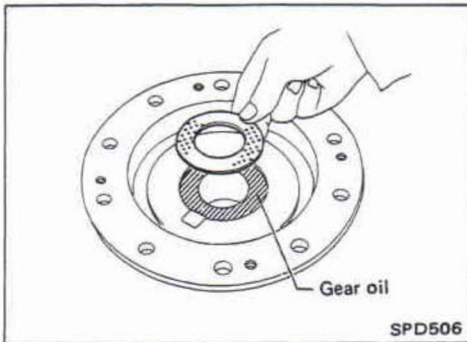

Assembly (Cont'd)

8. Install differential case A side components in the opposite way of differential case B components.
9. Apply gear oil to differential case A, and attach thrust washer to it.

10. Install differential case A on differential case B. Align the matching marks on the cases, then install screws while pushing differential case down using a press.

Press force:

7,846 N (800 kg, 1,764 lb)

11. After all parts have been assembled, check and adjust the following:

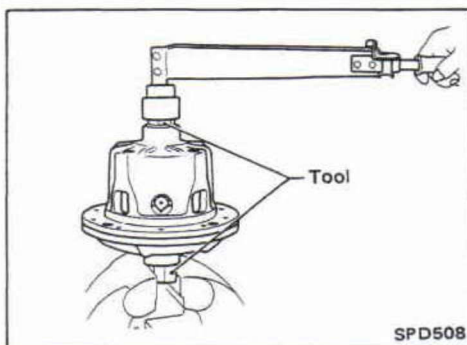

Differential torque inspection:

- a. Place side gear in a vise with Tool into the gear splines.
- b. Turn side gear several times, then measure the differential torque after side gear begins to rotate in order to determine whether it is within the specified range. If it is not, adjust it by selecting a friction disc. (Refer to S.D.S. for adjustment parts.)

Differential torque:

New parts

157 - 245 N·m (16 - 25 kg-m, 116 - 181 ft-lb)

Used parts

127 - 226 N·m (13 - 23 kg-m, 94 - 166 ft-lb)

Tool number:

KV38106400 (Except for Middle East)

KV38107100 (Middle East)

LIMITED SLIP DIFFERENTIAL (For H260)

Assembly (Cont'd)

Side gear backlash inspection:

Check backlash of side gear on both sides. Using a thickness gauge, measure clearance between side gear and thrust washer. If it is not within specifications, adjust it by selecting a thrust washer. (Refer to S.D.S.)

Side gear backlash:

Differential case A side

0.05 - 0.20 mm (0.0020 - 0.0079 in)

Differential case B side

0.05 - 0.20 mm (0.0020 - 0.0079 in)

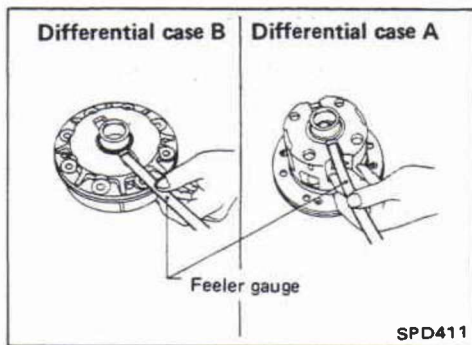

12. After checking and adjusting, tighten ring gear bolts in a criss-cross fashion.
13. Bend up lock straps to lock bolts in place.
14. Install side bearing inner race with Tool.

SERVICE DATA AND SPECIFICATIONS (S.D.S.)

Propeller Shaft

GENERAL SPECIFICATIONS

Item	Applied model	Hardtop	Wagon	Pickup
Propeller shaft model				
Front	2F80B		2F80B-D	
Rear	2F100H			
Number of joints		2		
Type of journal bearings		Solid (Disassembly type)		
Coupling type with transmission		Flange		
Distance between yokes				
Front	mm (in)	95 (3.74)		
Rear	mm (in)	108.0 (4.25)		
Shaft length (Spider-to-spider)				
Front	mm (in)	810.0 (31.89)		910.0 (35.83)
Rear	mm (in)	460.0 (18.11)	1,025.0 (40.35)	875.0 (34.45)
Shaft outer diameter				
Front	mm (in)	50.8 (2.000)		
Rear	mm (in)	82.6 (3.252)		

SERVICE DATA

Propeller shaft model		2F80B, 2F80B-D, 2F100H	
Propeller shaft runout limit	mm (in)	0.6 (0.024)	
Journal axial play	mm (in)	0.02 (0.0008)	

AVAILABLE SNAP RINGS 2F80B, 2F80B-D

Thickness mm (in)	Color	Part number
1.49 (0.0587)	White	39646-21001
1.52 (0.0598)	Yellow	39647-21001
1.55 (0.0610)	Red	39648-21001
1.58 (0.0622)	Green	39649-21001
1.61 (0.0634)	Blue	39646-21002
1.64 (0.0646)	Brown	39647-21002
1.67 (0.0657)	Black	39648-21002

2F100H

Thickness mm (in)	Color	Part number
1.95 (0.0768)	White	37146-61501
2.00 (0.0787)	Yellow	37147-61501
2.05 (0.0807)	Red	37148-61501
2.10 (0.0827)	Green	37149-61501
2.15 (0.0846)	Blue	37150-61501

SERVICE DATA AND SPECIFICATIONS (S.D.S.)

Differential Carrier

GENERAL SPECIFICATIONS

Hardtop and Wagon

Item	Applied model	Except models stated on the right	Deluxe models with TB42 engine and M/T, for Australia	
Final drive model		H233B		
Front		H233B		
Rear		H233B		
Number of pinions		2		
Front		2		
Rear		4		
Gear ratio	Standard	Option *1, *2	Standard	Option*3
	4.111	3.900	3.900	4.111
Number of teeth				
Ring gear	37	39	39	37
Drive pinion	9	10	10	9
Oil capacity (Approx.)		5.4 (4-3/4)		
Front		5.4 (4-3/4)		
ℓ (Imp qt)		5.4 (4-3/4)		
Rear		2.1 (1-7/8)		
ℓ (Imp qt)		2.1 (1-7/8)		

*1: Except for deluxe models with TD42 engine and M/T, and Hardtop models without rear seat

*2: For Gulf standard A/T models

*3: For Australia Wagon models only

Pickup

Item	Applied engine	TB42	TD42
Final drive model		H233B	
Front		H233B	
Rear		H260	
Number of pinions		4	
Front		4	
Rear		4	
Gear ratio		4.111	4.375
Number of teeth			
Ring gear		37	35
Drive pinion		9	8
Oil capacity (Approx.)		4.3 (3-3/4)	
Front		4.3 (3-3/4)	
ℓ (Imp qt)		4.3 (3-3/4)	
Rear		4.7 (4-1/8)	
ℓ (Imp qt)		4.7 (4-1/8)	

Differential Carrier — H233B

SERVICE DATA

Drive pinion bearing adjusting method	Pinion bearing adjusting washer
Backlash of pinion and ring gear mm (in)	0.15 - 0.20 (0.0059 - 0.0079)
Drive pinion preload N-m (kg-cm, in-lb)	
Without front oil seal	1.2 - 1.5 (12 - 15, 10 - 13)
With front oil seal	1.3 - 1.6 (13 - 16, 11 - 14)
Side bearing adjusting method	Side adjuster
Backlash of side gear and pinion mate gear mm (in)	0.15 - 0.20 (0.0059 - 0.0079)
Ring gear runout limit mm (in)	0.08 (0.0031)
Total preload N-m (kg-cm, in-lb)	1.8 - 2.5 (18 - 25, 16 - 22)

SERVICE DATA AND SPECIFICATIONS (S.D.S.)

Differential Carrier — H233B (Cont'd)

AVAILABLE WASHERS

Pinion height adjusting washer

Thickness mm (in)	Part number
2.58 (0.1016)	38151-01J00
2.61 (0.1028)	38151-01J01
2.64 (0.1039)	38151-01J02
2.67 (0.1051)	38151-01J03
2.70 (0.1063)	38151-01J04
2.73 (0.1075)	38151-01J05
2.76 (0.1087)	38151-01J06
2.79 (0.1098)	38151-01J07
2.82 (0.1110)	38151-01J08
2.85 (0.1122)	38151-01J09
2.88 (0.1134)	38151-01J10
2.91 (0.1146)	38151-01J11
2.94 (0.1157)	38151-01J12
2.97 (0.1169)	38151-01J13
3.00 (0.1181)	38151-01J14
3.03 (0.1193)	38151-01J15
3.06 (0.1205)	38151-01J16
3.09 (0.1217)	38151-01J17
3.12 (0.1228)	38151-01J18
3.15 (0.1240)	38151-01J19
3.18 (0.1252)	38151-01J60
3.21 (0.1264)	38151-01J61
3.24 (0.1276)	38151-01J62
3.27 (0.1287)	38151-01J63
3.30 (0.1299)	38151-01J64
3.33 (0.1311)	38151-01J65
3.36 (0.1323)	38151-01J66
3.39 (0.1335)	38151-01J67
3.42 (0.1346)	38151-01J68
3.45 (0.1358)	38151-01J69
3.48 (0.1370)	38151-01J70
3.51 (0.1382)	38151-01J71
3.54 (0.1394)	38151-01J72
3.57 (0.1406)	38151-01J73
3.60 (0.1417)	38151-01J74
3.63 (0.1429)	38151-01J75
3.66 (0.1441)	38151-01J76

Pinion bearing adjusting washer

Thickness mm (in)	Part number
0.40 (0.0157)	24127-4301P
0.45 (0.0177)	24127-4302P
0.50 (0.0197)	24127-4303P
0.55 (0.0217)	24127-4304P
0.60 (0.0236)	24127-4305P
0.65 (0.0256)	24127-4306P
0.70 (0.0276)	24127-4307P
0.75 (0.0295)	24127-4308P

Side gear thrust washer

Thickness mm (in)	Part number
1.75 (0.0689)	38424-T5000
1.80 (0.0709)	38424-T5001
1.85 (0.0728)	38424-T5002

TIGHTENING TORQUE

Unit	N·m	kg·m	ft·lb
Rear differential carrier to axle case			
Wagon and Hardtop	54 - 64	5.5 - 6.5	40 - 47
Pickup	33 - 40	3.4 - 4.1	25 - 30
Front differential carrier to axle case			
	54 - 64	5.5 - 6.5	40 - 47

SERVICE DATA AND SPECIFICATIONS (S.D.S.)

Differential Carrier — H260

SERVICE DATA

Drive pinion bearing adjusting method	Pinion bearing adjusting washer
Backlash of pinion and ring gear mm (in)	0.15 - 0.20 (0.0059 - 0.0079)
Drive pinion preload N-m (kg-cm, in-lb)	
Without front oil seal	1.2 - 1.5 (12 - 15, 10 - 13)
With front oil seal	1.5 - 1.7 (15 - 17, 13 - 15)
Side bearing adjusting method	Side adjuster
Backlash of side gear and pinion mate gear mm (in)	0.15 - 0.20 (0.0059 - 0.0079)
Ring gear runout limit mm (in)	0.08 (0.0031)
Total preload N-m (kg-cm, in-lb)	1.7 - 2.5 (17 - 25, 15 - 22)

For limited slip differential model

The differences between limited slip differential model and conventional model are shown below.

Side gear backlash (Clearance between side gear and thrust washer) mm (in)	0.05 - 0.30 (0.0020 - 0.0118)
Differential torque N-m (kg-m, ft-lb)	
New parts	157 - 245 (16 - 25, 116 - 181)
Used parts	127 - 226 (13 - 23, 94 - 166)
Allowable warpage for friction discs and plates mm (in)	0.08 (0.0031)
Wear limit for discs and plates mm (in)	0.1 (0.004)
Wear limit for thrust washer mm (in)	0.1 (0.004)

AVAILABLE WASHERS

Pinion height adjusting washer

Thickness mm (in)	Part number
2.60 (0.1024)	38153-82101
2.63 (0.1035)	38153-82102
2.66 (0.1047)	38153-82103
2.69 (0.1059)	38153-82104
2.72 (0.1071)	38153-82105
2.75 (0.1083)	38153-82106
2.78 (0.1094)	38153-82107
2.81 (0.1106)	38153-82108
2.84 (0.1118)	38153-82109
2.87 (0.1130)	38153-82110
2.90 (0.1142)	38153-82111
2.93 (0.1154)	38153-82112
2.96 (0.1165)	38153-82113
2.99 (0.1177)	38153-82114
3.02 (0.1189)	38153-82115
3.05 (0.1201)	38153-82116
3.08 (0.1213)	38153-82117
3.11 (0.1224)	38153-82118
3.14 (0.1236)	38153-82119
3.17 (0.1248)	38153-82120

Pinion bearing adjusting washer

Thickness mm (in)	Part number
2.31 (0.0909)	38125-82100
2.33 (0.0917)	38126-82100
2.35 (0.0925)	38127-82100
2.37 (0.0933)	38128-82100
2.39 (0.0941)	38129-82100
2.41 (0.0949)	38130-82100
2.43 (0.0957)	38131-82100
2.45 (0.0965)	38132-82100
2.47 (0.0972)	38133-82100
2.49 (0.0980)	98134-82100
2.51 (0.0988)	38135-82100
2.53 (0.0996)	38136-82100
2.55 (0.1004)	38137-82100
2.57 (0.1012)	38138-82100
2.59 (0.1020)	38139-82100

Pinion bearing adjusting spacer

Thickness mm (in)	Part number
4.50 (0.1772)	38165-76000
4.75 (0.1870)	38166-76000
5.00 (0.1969)	38167-76000

SERVICE DATA AND SPECIFICATIONS (S.D.S.)

Differential Carrier — H260 (Cont'd)

Side gear thrust washer

Conventional model

Thickness mm (in)	Part number
1.55 (0.0610)	38424-61500
1.60 (0.0630)	38424-61501
1.65 (0.0650)	38424-61502

Limited slip differential model

Thickness mm (in)	Color	Part number
1.58 - 1.62 (0.0622 - 0.0638)	—	38424-35010
1.43 - 1.47 (0.0563 - 0.0579)	White	38424-C8700
1.73 - 1.77 (0.0681 - 0.0697)	Yellow	38424-C8701

AVAILABLE DISCS AND PLATES FOR LIMITED SLIP DIFFERENTIAL

Part name	Thickness mm (in)	Part number
Friction disc	2.38 - 2.42 (0.0937 - 0.0953)	38433-C8700
	2.38 - 2.42 (0.0937 - 0.0953)	38432-C8700
Friction plate	2.48 - 2.52 (0.0976 - 0.0992)	38432-C8701
	2.38 - 2.42 (0.0937 - 0.0953)	38435-76010
Spring plate	2.38 - 2.42 (0.0937 - 0.0953)	38435-76010

TIGHTENING TORQUE

Unit	N-m	kg-m	ft-lb
Differential carrier to axle case	27 - 36	2.8 - 3.7	20 - 27