

STEERING SYSTEM

SECTION **ST**

CONTENTS

PRECAUTIONS	ST- 2
PREPARATION	ST- 3
ON-VEHICLE INSPECTION	ST- 5
ON-VEHICLE INSPECTION (Power Steering)	ST- 6
STEERING WHEEL AND STEERING COLUMN	ST- 8
MANUAL STEERING GEAR (Model: VB70S)	ST-12
POWER STEERING GEAR (Model: PB56SC)	ST-18
POWER STEERING OIL PUMP	ST-25
STEERING LINKAGE	ST-29
SERVICE DATA AND SPECIFICATIONS (S.D.S.)	ST-31

PRECAUTIONS

- Before disassembly, thoroughly clean the outside of the unit.
- Disassembly should be done in a clean work area. It is important to prevent the internal parts from becoming contaminated by dirt or other foreign matter.
- When disassembling parts, be sure to place them in order in a parts rack so they can be reinstalled in their proper positions.
- Before inspection or reassembly, carefully clean all parts with a general purpose, non-flammable solvent.
- Replace all gaskets, seals and O-rings.
Avoid damaging O-rings, seals and gaskets during installation. Perform functional tests whenever designated.
- Use nylon cloths or paper towels to clean the parts; common shop rags can leave lint that might interfere with their operation.





For power steering:

- Before assembly, apply a coat of recommended A.T.F. ★ to hydraulic parts.
Vaseline may be applied to O-rings and seals.
Do not use any grease.
- ★: Automatic transmission fluid

PREPARATION

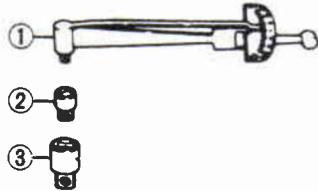
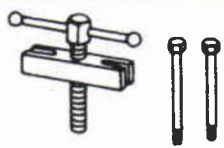
SPECIAL SERVICE TOOLS

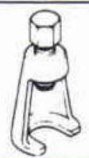
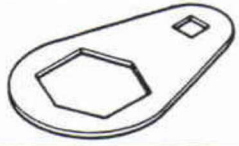
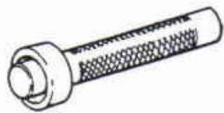
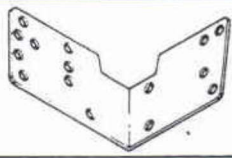
*: Special tool or commercial equivalent

Tool number Tool name	Description	Unit application	
		Manual steering	Power steering
ST3127S000* ① GG91030000 Torque wrench ② HT62940000 Socket adapter ③ HT62900000 Socket adapter	 <p style="text-align: right;">Measuring turning torque</p>	X	X
ST27180001* Steering wheel puller	 <p style="text-align: right;">Removing steering wheel</p>	X	X
HT72520000* Ball joint remover	 <p style="text-align: right;">Removing ball joint</p>	X	X
ST29020001* Steering gear arm puller	 <p style="text-align: right;">Removing pitman arm</p>	X	X
KV48101500 Lock nut wrench		X	-
ST33210000 Gear carrier side bearing drift		X	-
KV48100301* Strut and steering gearbox attachment	 <p style="text-align: right;">Attaching steering gear</p>	X	X
KV48100700 Torque adapter		X	X

PREPARATION

*: Special tool or commercial equivalent

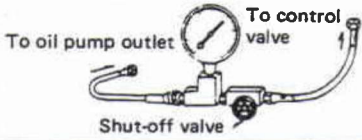
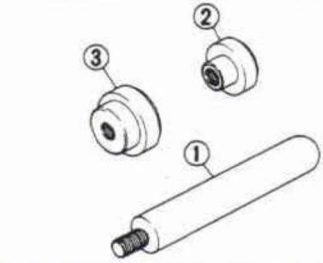
Tool number Tool name	Description	Unit application	
		Manual steering	Power steering
ST27091000* Pressure gauge	 <p>Measuring oil pressure</p>	-	X
KV481009S0 Oil seal drift set ① KV48100910 Drift ② KV48100920 Adapter ③ KV48100930 Adapter	 <p>Installing oil seal</p>	-	X

ON-VEHICLE INSPECTION

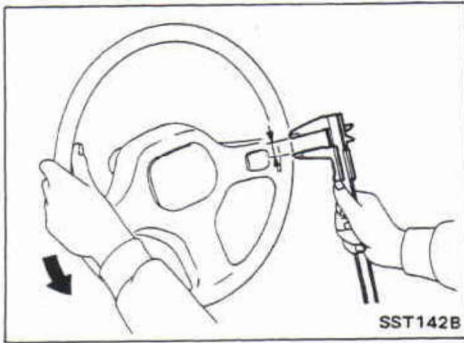

Checking Steering Wheel Play

- With wheels in a straight-ahead position, check steering wheel play.

Steering wheel play:

35 mm (1.38 in) or less

- If it is not within specification, check tie-rod outer and inner ball joints.

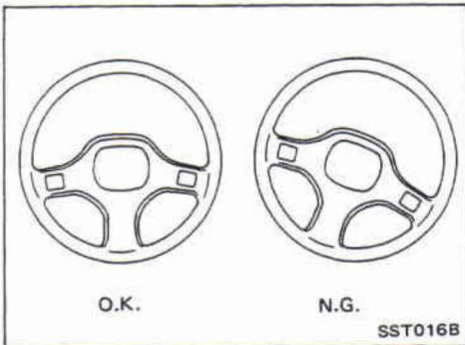

Checking Neutral Position on Steering Wheel

Pre-checking

- Verify that the steering gear is centered before removing the steering wheel.

Checking

- Check that the steering wheel is in the neutral position when driving straight ahead.
- If it is not in the neutral position, remove the steering wheel and re-install it correctly.
- If the neutral position is between two serrated teeth, loosen tie-rod lock nut and move tie-rod in the opposite direction by the same amount on both left and right sides to compensate for error in the neutral position.

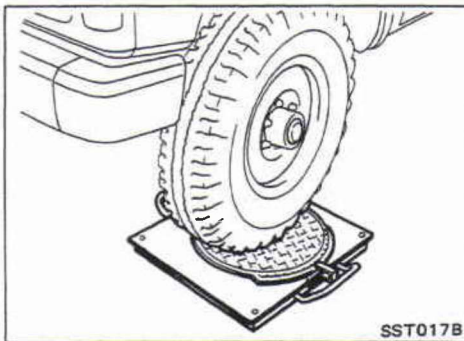

Checking Front Wheel Turning Angle

- Rotate steering wheel all the way right and left; measure turning angle.

Turning angle:

Full turns and toe-out turn

Refer to section FA for S.D.S.

ON-VEHICLE INSPECTION (Power Steering)

Checking and Adjusting Drive Belts

Refer to section MA for Drive Belt Inspection.

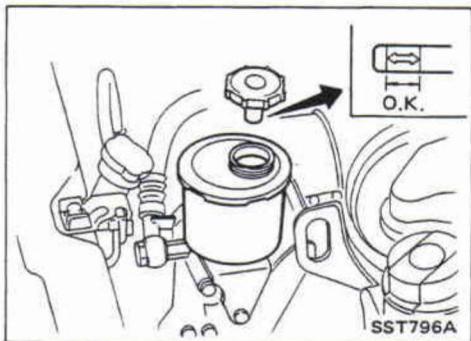

Checking Fluid Level

Check the level when the fluid is cold.

CAUTION:

- Do not overfill.
- Recommended fluid is Automatic Transmission Fluid "Dexron Type".

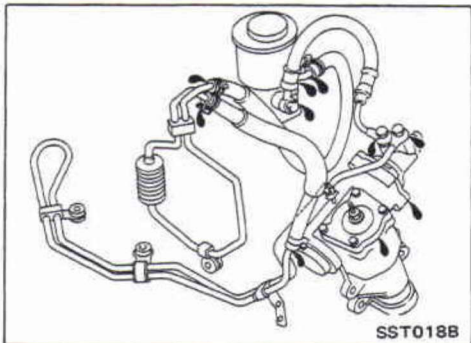

Checking Fluid Leakage

Check the lines for improper attachment and for leaks, cracks, damage, loose connections, chafing or deterioration.

1. Run engine at idle speed or 1,000 rpm.

Make sure temperature of fluid in oil tank rises to 60 to 80°C (140 to 176°F).

2. Turn steering wheel right-to-left several times.
3. Hold steering wheel at each "lock" position for five seconds and carefully check for fluid leakage.

CAUTION:

Do not hold the steering wheel in a locked position for more than 15 seconds.

4. If fluid leakage at connectors is noticed, loosen flare nut and then retighten.

Do not overtighten connector as this can damage O-ring, washer and connector.

Bleeding Hydraulic System

1. Raise front end of vehicle until wheels clear ground.
2. Add fluid into oil tank. Meanwhile quickly turn steering wheel fully to right and left and lightly touch steering stoppers. Repeat above operation until fluid level no longer decreases.
3. Start engine.
Repeat step 2 above.
 - Incomplete air bleeding will cause the following to occur. When this happens, bleed air again.
 - ① Generation of air bubbles in oil tank
 - ② Generation of clicking noise in oil pump
 - ③ Excessive buzzing in oil pump

ON-VEHICLE INSPECTION (Power Steering)

Bleeding Hydraulic System (Cont'd)

While the vehicle is stationary or while moving the steering wheel slowly, fluid noise may occur in the valve or oil pump. This noise is inherent in this steering system, and it will not affect performance or durability of the system.

Checking Steering Wheel Turning Force

1. Park vehicle on a level, dry surface and set parking brake.
2. Bring power steering fluid up to adequate operating temperature. [Make sure temperature of fluid is approximately 60 to 80°C (140 to 176°F).]

Tires need to be inflated to normal pressure.

3. Check steering wheel turning force when steering wheel has been turned 360° from neutral position.

Steering wheel turning force:

39 N (4 kg, 9 lb) or less

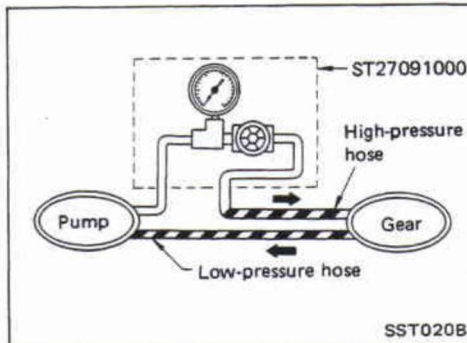
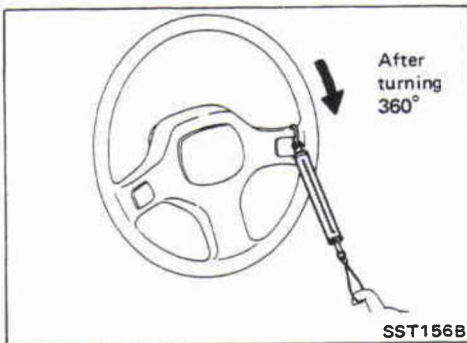

Checking Hydraulic System

Before starting, check belt tension, driving pulley and tire pressure.

1. Set Tool. Open shut-off valve. Then bleed air. (See "Bleeding Hydraulic System".)
2. Run engine.

Make sure temperature of fluid in tank rises to 60 to 80°C (140 to 176°F).

WARNING:

Warm up engine with shut-off valve fully opened. If engine is started with shut-off valve closed, oil pressure in oil pump will increase to relief pressure, resulting in an abnormal rise in oil temperature.

3. Check pressure with steering wheel fully turned to left and right positions.

CAUTION:

Do not hold the steering wheel in a locked position for more than 15 seconds.

Oil pump standard pressure:

8,630 - 9,219 kPa

**(86.3 - 92.2 bar, 88 - 94 kg/cm², 1,251 - 1,337 psi)
at idling**

4. If oil pressure is below the standard level, slowly close shut-off valve and check pressure.
 - When pressure reaches standard level, gear is damaged.
 - When pressure remains below standard level, pump is damaged.
5. If oil pressure is higher than the standard level, pump is damaged.

CAUTION:

Do not close shut-off valve for more than fifteen seconds.

6. After checking hydraulic system, remove Tool and add fluid as necessary, then completely bleed air out of system.

STEERING WHEEL AND STEERING COLUMN

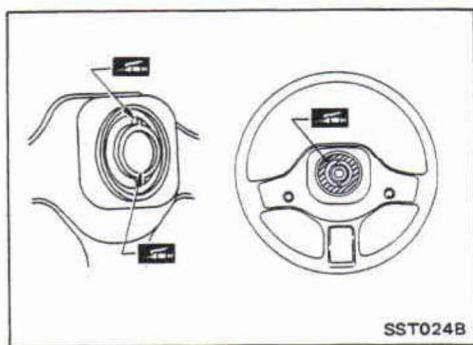

Installation

STEERING WHEEL

- When installing steering wheel, apply multi-purpose grease to entire surface of turn signal cancel pin (both portions) and also to horn contact slip ring.

STEERING COLUMN

- When installing steering column, fingertighten all lower bracket and clamp retaining bolts; then tighten them securely. Do not apply undue stress to steering column.

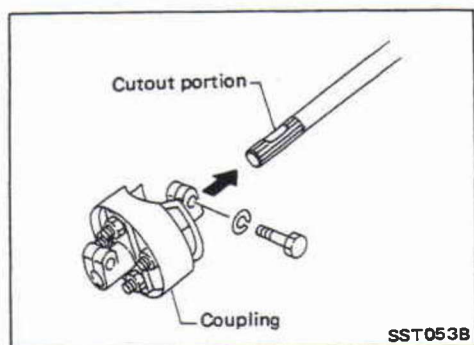

- When attaching coupling, be sure tightening bolt faces cutout portion.

CAUTION:

After installing steering column, turn steering wheel to make sure it moves smoothly and that the number of turns from the straight forward position to left and right locks are equal.

STEERING WHEEL AND STEERING COLUMN

Disassembly and Assembly

CAUTION:

After installing, turn steering wheel to make sure it moves smoothly and that the number of turns from the straight forward position to left and right locks are equal.

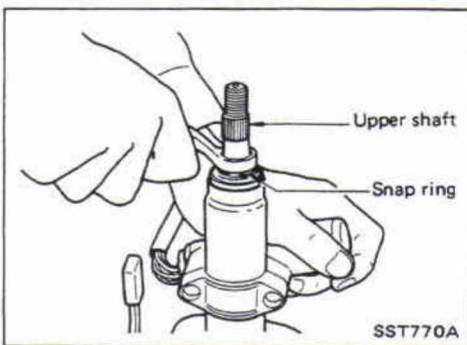
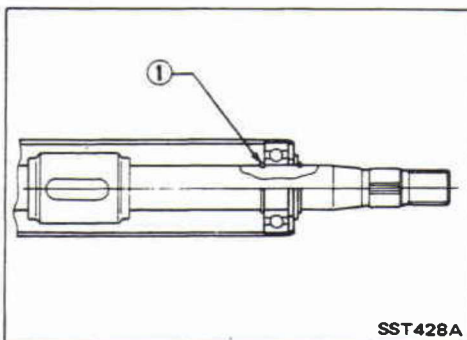
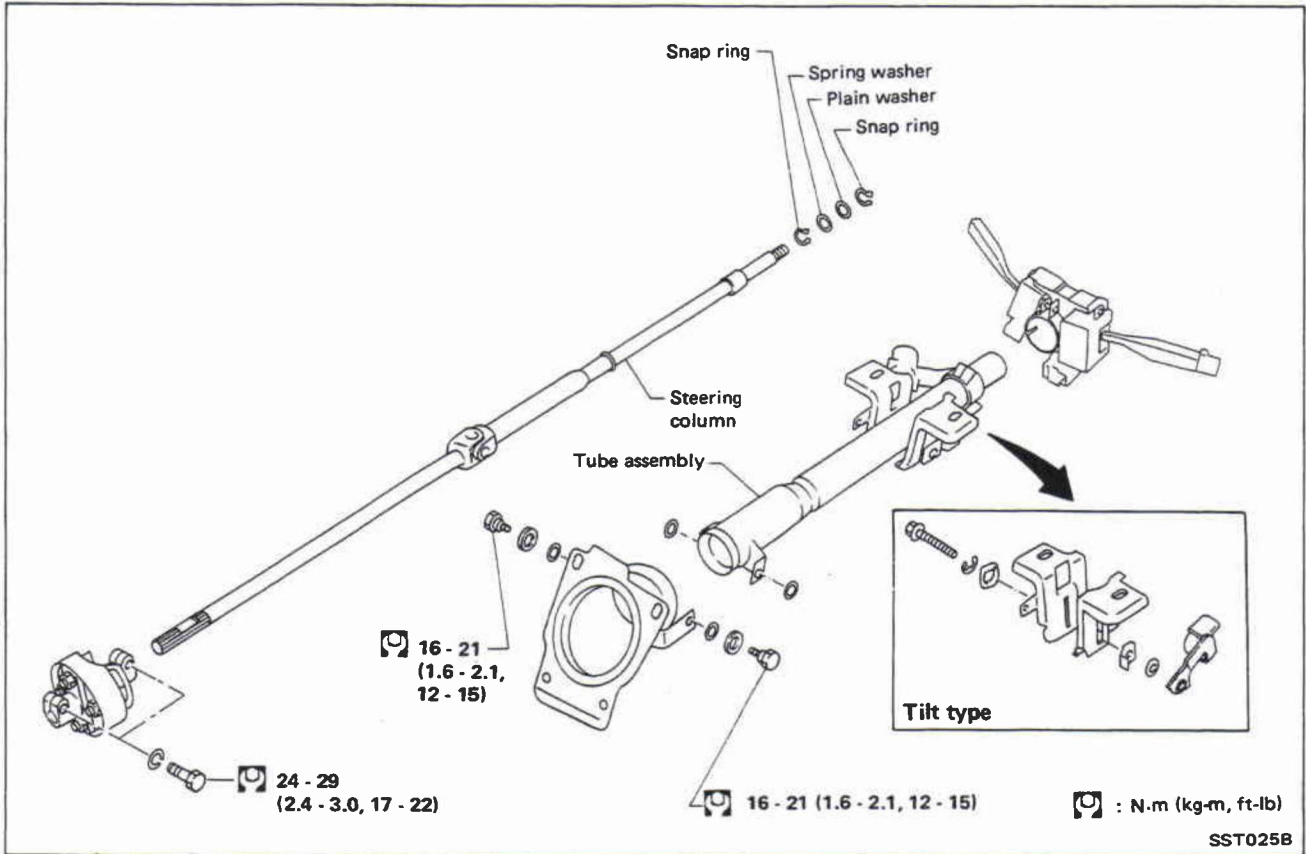

- When disassembling and assembling, unlock steering lock with key.
- Ensure that rounded surface of snap ring faces toward bearing when snap ring is installed.
- Install snap ring ① before inserting shaft into jacket tube.

- Install snap ring on upper shaft with box wrench.

STEERING WHEEL AND STEERING COLUMN

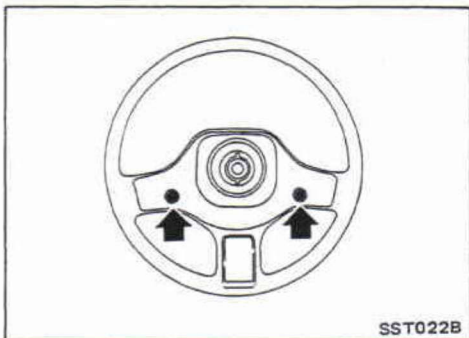
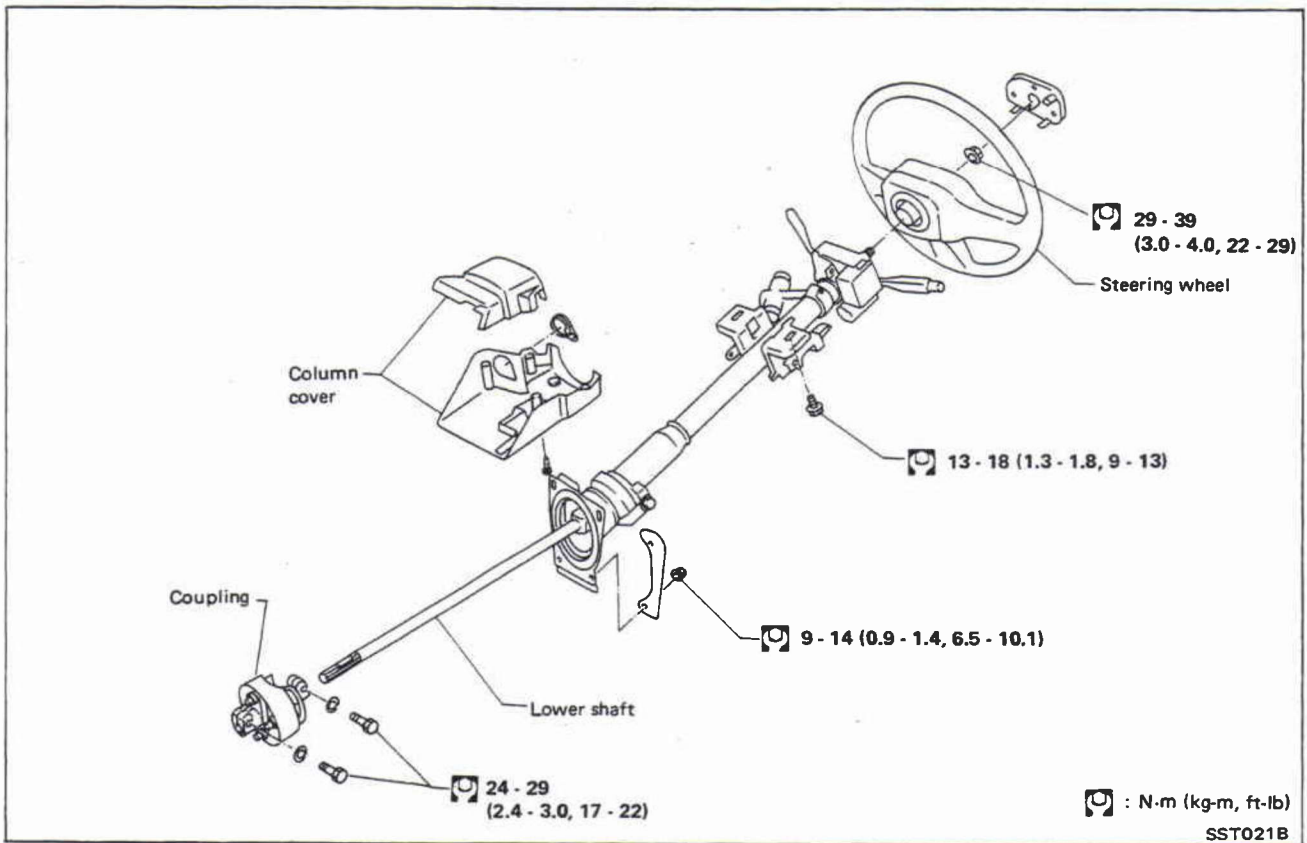

Removal STEERING WHEEL

- Remove two screws from the rear of steering wheel.



- Remove steering wheel with Tool.

STEERING WHEEL AND STEERING COLUMN

Disassembly and Assembly (Cont'd)

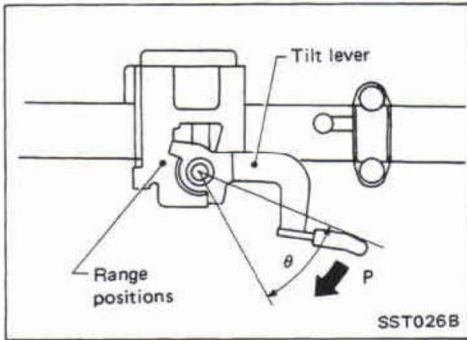

- Adjust tilt lever as follows.

- (1) When tilt lever contacts flange portion, tighten adjusting bolt.
- (2) Turn tilt lever by 90° (θ) in direction "P" to check that steering column moves smoothly without binding.
- (3) Return tilt lever to position θ . Make sure there is no free play (=0) of steering column when steering wheel is pushed down by force.

- Steering lock

- a) Break self-shear type screws with a drill or other appropriate tool.

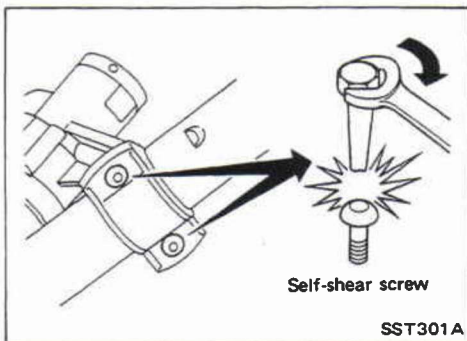

- b) Install self-shear type screws and then cut off self-shear type screw heads.

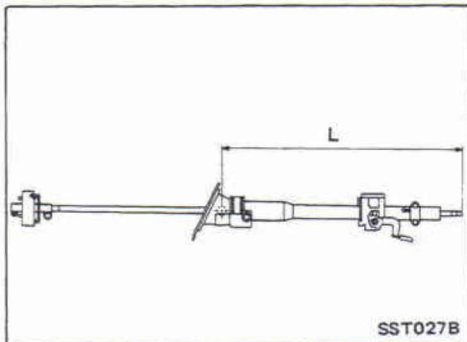

Inspection

- When steering wheel can not be rotated smoothly, check the steering column for the following matters and replace damaged parts.

- (1) Check column bearings for damage or unevenness. Lubricate with recommended multi-purpose grease or replace steering column as an assembly, if necessary.
- (2) Check jacket tube for deformation or breakage. Replace if necessary.

- When the vehicle is involved in a light collision, check dimension "L". If it is not within specifications, replace steering column as an assembly.*

Column length "L":

$$L = 681.6 - 683.2 \text{ mm (26.83 - 26.90 in)}$$

*: Models for only Middle East
Except for Pickup model

MANUAL STEERING GEAR (Model: VB70S)

Removal and Installation

VB70S

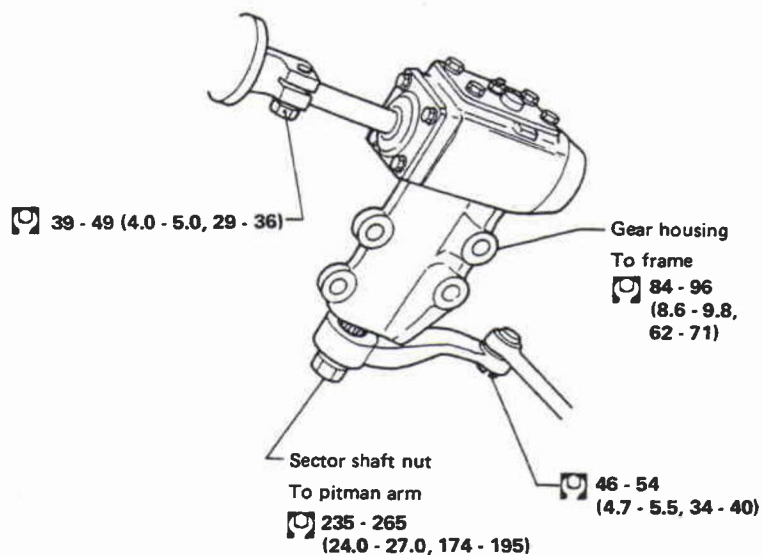

: N·m (kg·m, ft·lb)

SST0548

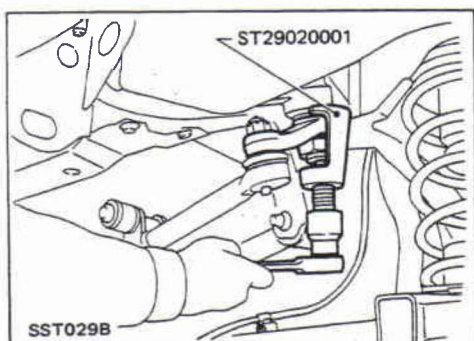

- Remove pitman arm with Tool.
- When installing, align four grooves of gear serrations with four projections of sector shaft serrations. When fitting steering lower joint, be sure tightening bolt faces cutout portion perfectly.

MANUAL STEERING GEAR (Model: VB70S)

Disassembly

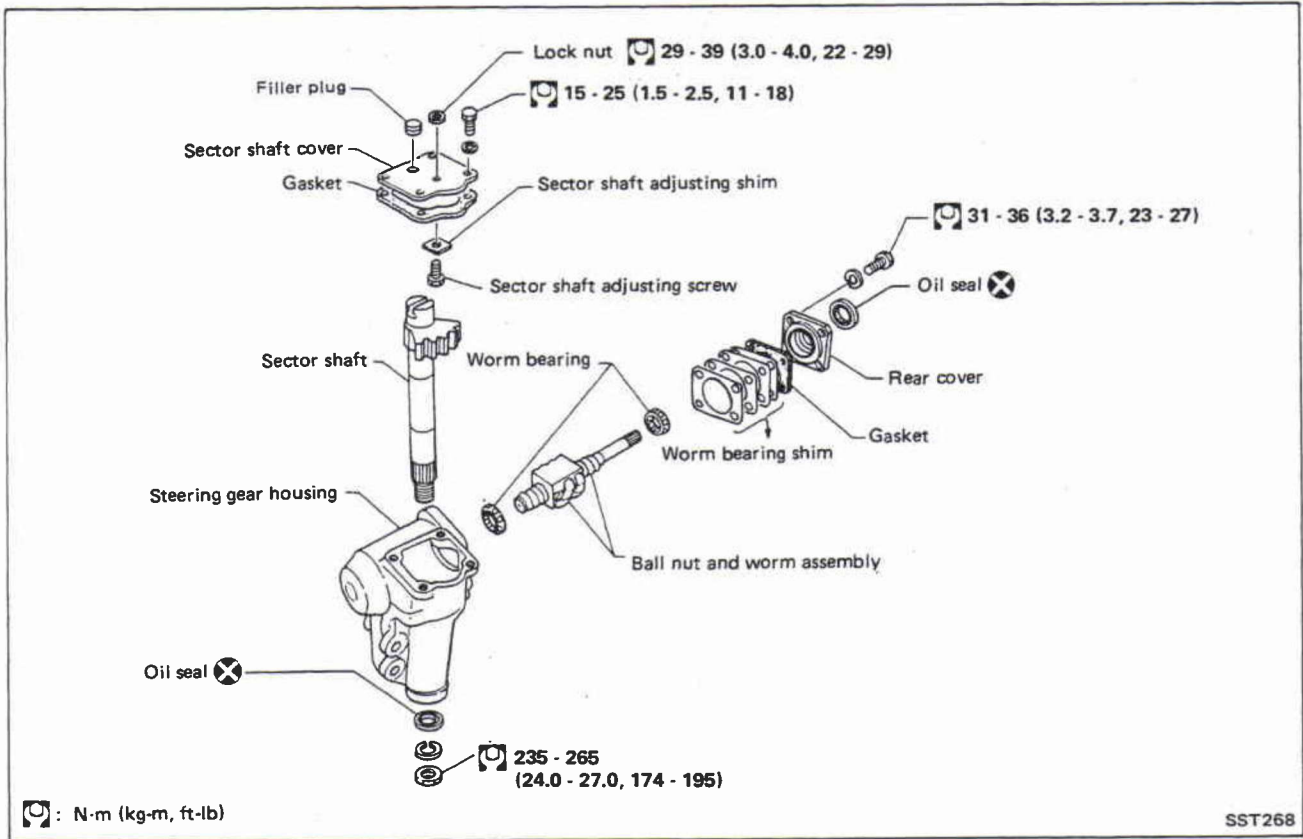

CAUTION:

Thoroughly drain oil by removing filler plug.

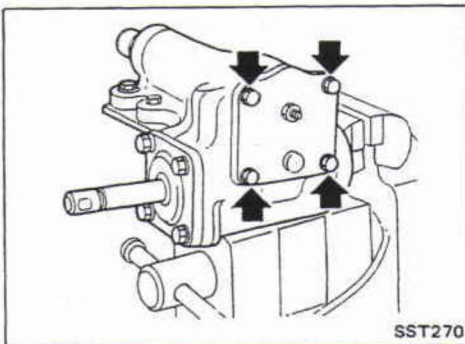

1. Place steering gear in a vise with Tool in place.
 - Remove sector shaft cover fixing bolts.

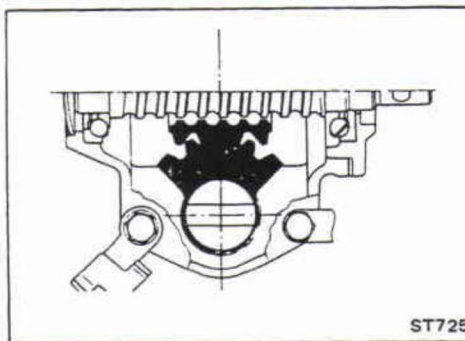

- Set worm gear in a straight-ahead position.

MANUAL STEERING GEAR (Model: VB70S)

Disassembly (Cont'd)

- Remove sector shaft with sector shaft cover.

CAUTION:

- a. When pulling sector shaft out, be careful not to damage oil seal or associated parts.
- b. Set worm gear in a straight-ahead position.

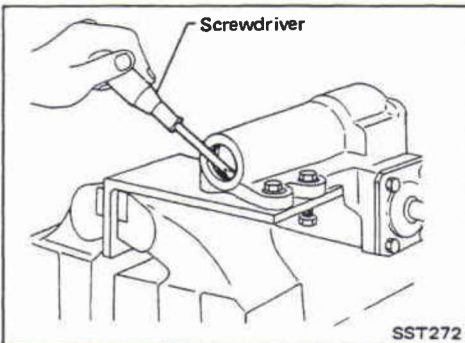
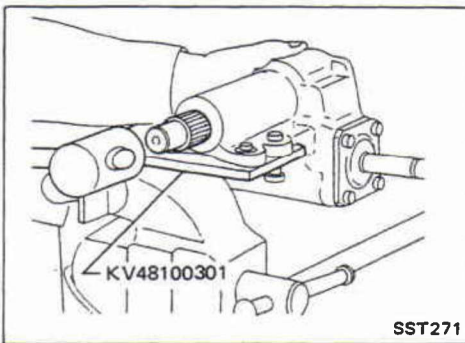

- Remove sector shaft oil seal, if necessary.

2. Remove rear cover.

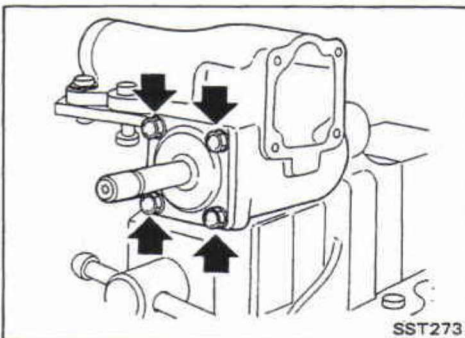

3. Draw out worm gear with worm bearing.

CAUTION:

- a. Be careful not to allow ball nut to run down to either end of worm.
Ends of ball guides will be damaged if nut is rotated until it stops at end of worm.
- b. Do not detach ball nut from worm shaft assembly.
If necessary, replace entire unit as an assembly.
- c. Do not remove sector shaft needle bearings from steering gear housing.
If necessary, replace entire gear housing as an assembly.

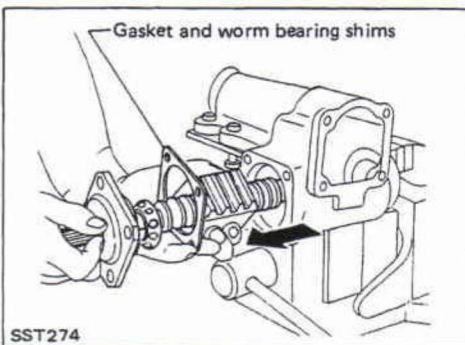

MANUAL STEERING GEAR (Model: VB70S)

Disassembly (Cont'd)

- Remove oil seal from rear cover.

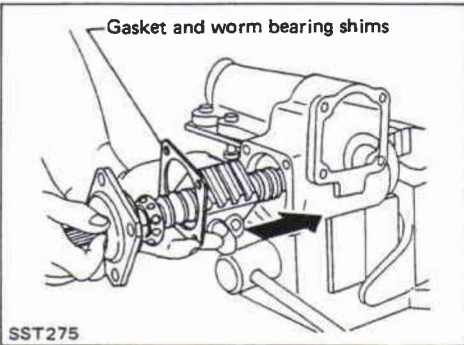
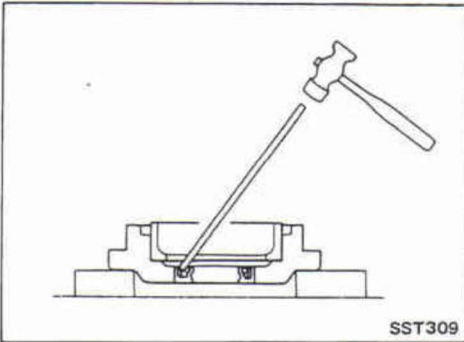

Assembly and Adjustment

Fill space sealing lips of new sector shaft and rear cover oil seals with multi-purpose grease.

Worm bearing preload

1. Fit worm gear assembly with worm bearing in gear housing.
2. Install rear cover on gear housing with gasket and worm bearing shims.

Standard shim thickness:

1.0 mm (0.039 in)

Available worm bearing shims:

Refer to S.D.S.

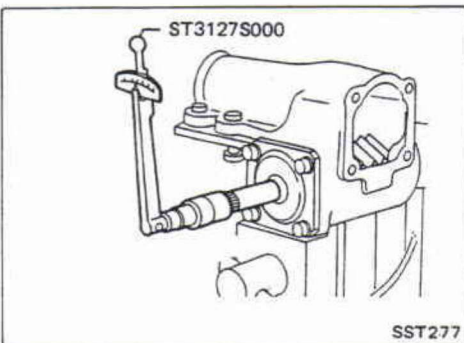

3. Adjust worm bearing preload with Tools.

CAUTION:

- Rotate worm shaft a few turns in both directions to correctly settle worm bearing and measure preload.
- When adjusting worm bearing preload, add or remove shims until correct adjustment is achieved.
- After correct adjustment is achieved, install oil seal in rear cover.

Worm bearing preload (With oil seal):

0.39 - 0.59 N·m (4.0 - 6.0 kg-cm, 3.5 - 5.2 in-lb)

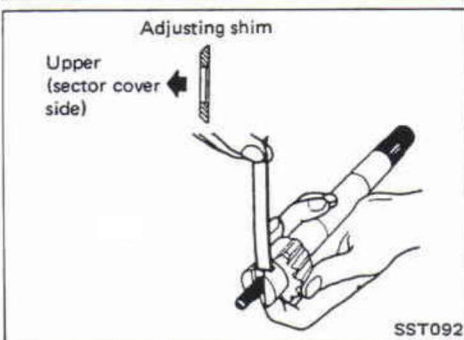

SECTOR SHAFT END PLAY

Select suitable adjusting shim and adjust end play between sector shaft and adjusting screw.

Sector shaft end play:

0.01 - 0.03 mm (0.0004 - 0.0012 in)

Sector shaft adjusting screw shims:

Refer to S.D.S.

MANUAL STEERING GEAR (Model: VB70S)

Assembly and Adjustment (Cont'd) STEERING GEAR PRELOAD AND BACKLASH

1. Press oil seal to steering gear housing using Tool.
Before pressing oil seal, coat seal contacting face of oil seal with gear fluid.

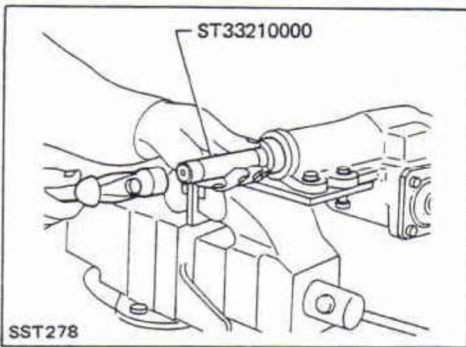

2. Install sector cover on adjusting screw with sector shaft.
3. Set worm gear in a straight-ahead position.
4. Insert sector shaft and sector cover assembly with gasket into gear housing.
Carefully insert sector shaft in place, using care not to scratch oil seal.

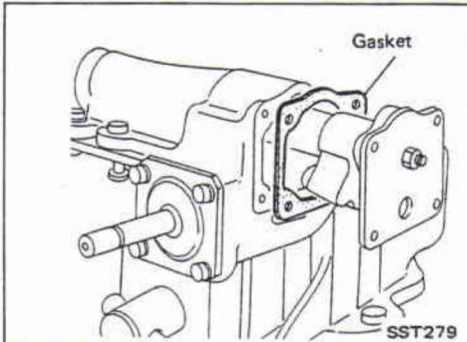

5. Tighten sector cover to gear housing.

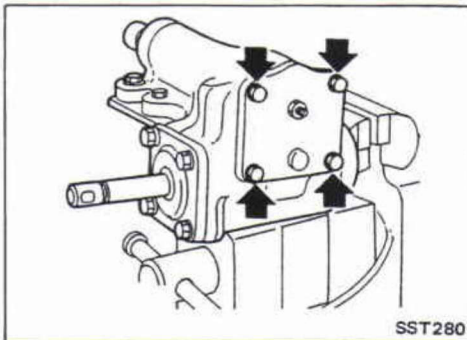

6. Adjust backlash as shown in figure.
Rotate worm gear a few turns in both directions to settle down steering gear and in straight-ahead position, and then measure backlash at pitman arm top end.

Backlash (In straight-ahead position):
0 - 0.1 mm (0 - 0.004 in)

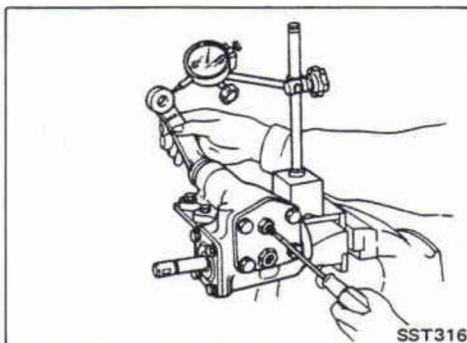

7. Measure total preload.

Steering gear total preload (With oil seals):

New parts

0.83 - 1.23 N·m (8.5 - 12.5 kg-cm, 7.4 - 10.9 in-lb)

Used parts

0.59 - 0.98 N·m (6.0 - 10.0 kg-cm, 5.2 - 8.7 in-lb)

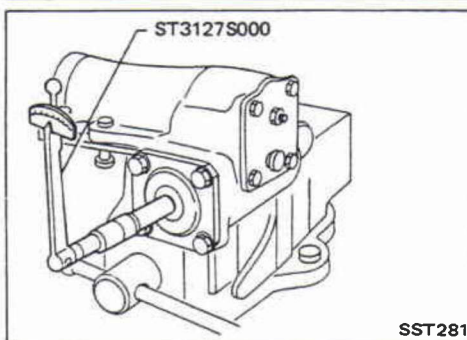

MANUAL STEERING GEAR (Model: VB70S)

Inspection

Clean all parts in solvent, then check their condition.

SECTOR SHAFT

1. Check gear tooth surface for pitting, burrs, cracks or any other damage, and replace if necessary.
2. Check sector shaft for distortion on its serration, and replace if necessary. Also check gear housing for deformation.

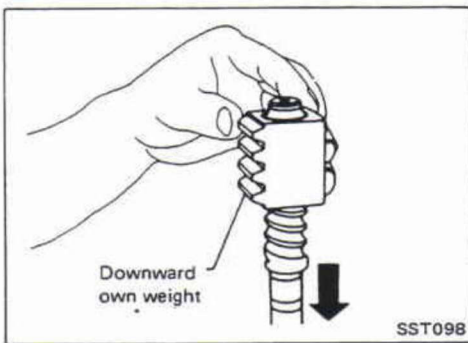

STEERING WORM ASSEMBLY

1. Inspect ball nut gear tooth surface, and replace if pitting, burrs, wear or any other damage is found.
2. Ball nut must rotate smoothly on worm gear. If found too tight, assembly should be replaced. Check rotation of ball nut as follows:
 - (1) Move ball nut to either end of worm gear, and gradually stand worm shaft and ball nut assembly until ball nut moves downward on worm gear under its own weight.
 - (2) If ball nut does not move freely over entire stroke, replace assembly.

Be careful not to damage ball nut guide tube while check is being made.

CAUTION:

Be careful not to allow ball nut to run down to either end of worm.

BEARING

1. Check worm bearing to see that it rolls freely and is free from noise, cracks, pitting or wear.

When replacing worm bearing, replace it as a set of bearing and outer race.

2. If sector shaft needle bearings are worn or damaged, replace as an assembly of gear housing and bearings.

OIL SEALS

- Discard any oil seal which has once been removed.
- Replace oil seal if sealing lip is deformed or cracked.
- Discard oil seal if spring is fatigued or dislocated.

POWER STEERING GEAR (Model: PB56SC)

Removal and Installation

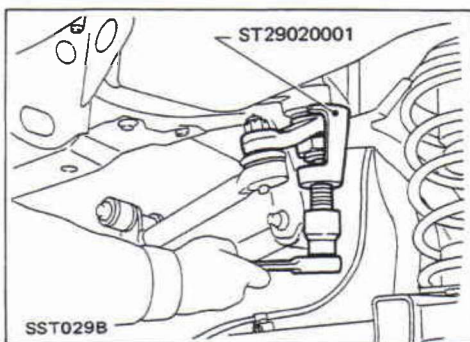
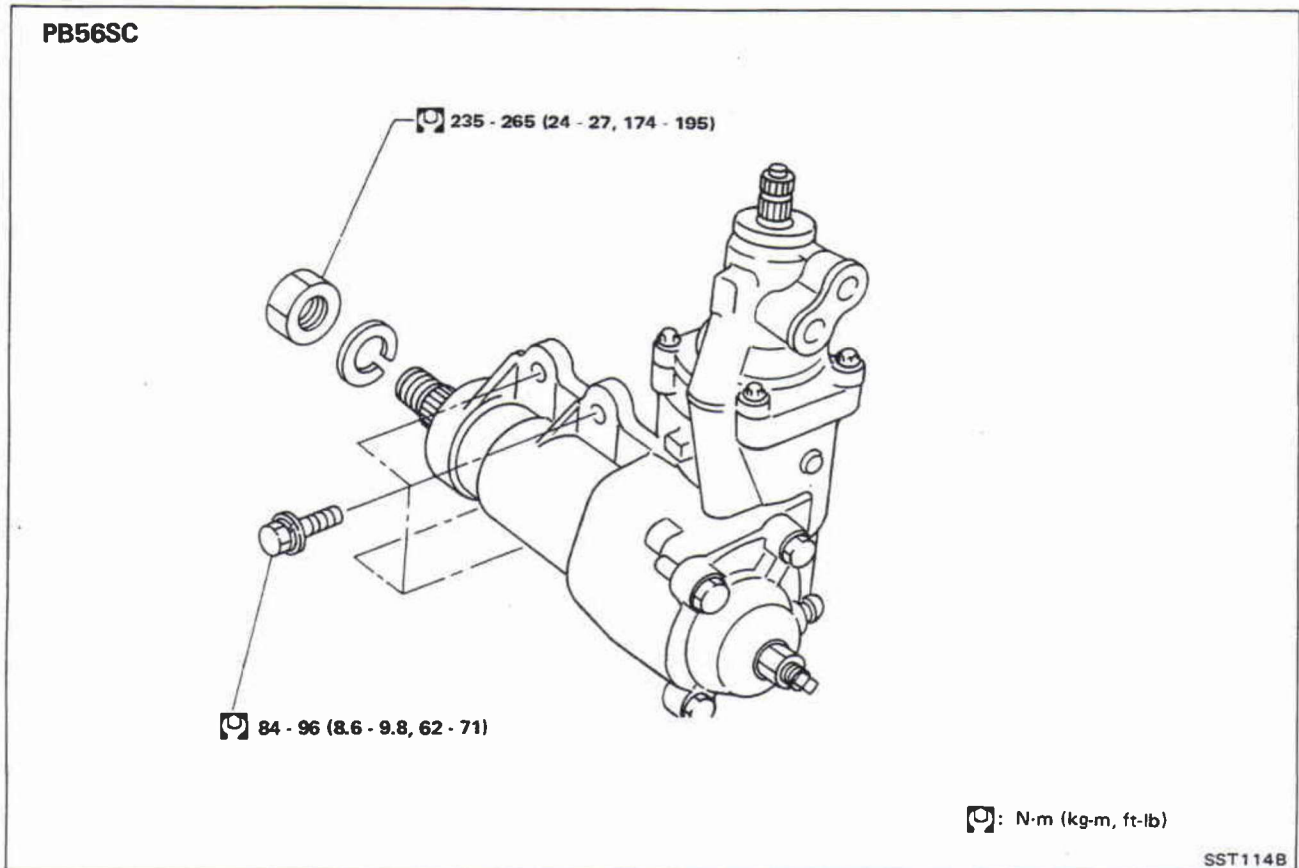

- Remove pitman arm with Tool.
- When installing, align four grooves of gear serrations with four projections of sector shaft serrations.

- Before removing, clean exteriors of gear housing and oil pump with steam and dry with compressed air.

POWER STEERING GEAR (Model: PB56SC)

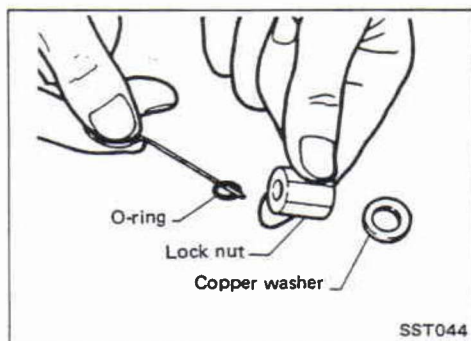
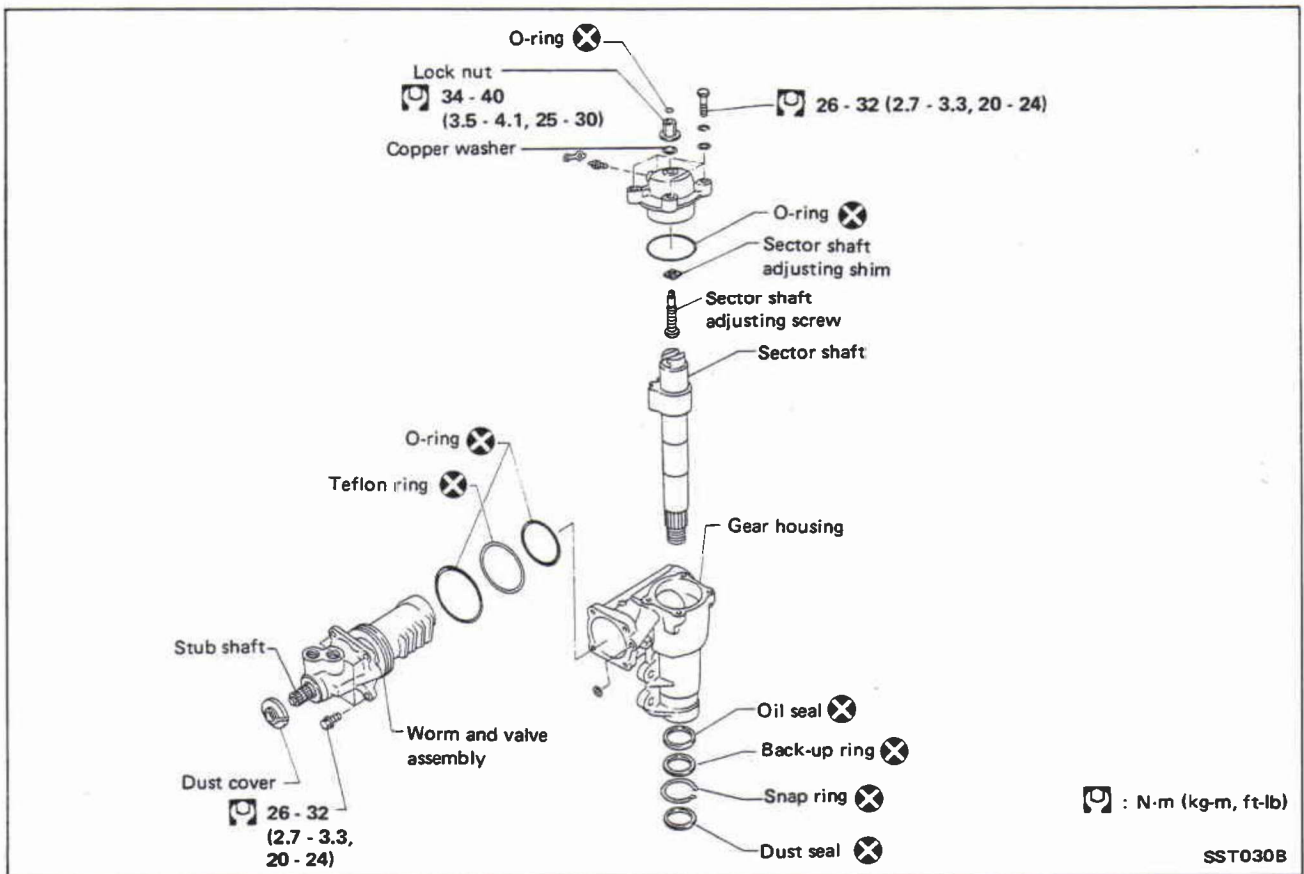

Disassembly

ADJUSTING SCREW LOCK NUT O-RING

Remove adjusting screw lock nut, and replace O-ring.

SECTOR SHAFT OIL SEAL AND DUST SEAL

1. Set stub shaft in a straight-ahead position.
Straight-ahead position is a position where stub shaft is turned 1.85 turns (one full turn and 306°) from lock position.

POWER STEERING GEAR (Model: PB56SC)

Disassembly (Cont'd)

2. Disconnect sector shaft cover bolt.
Do not turn lock nut unless necessary; otherwise it will damage O-ring, resulting in an oil leak.

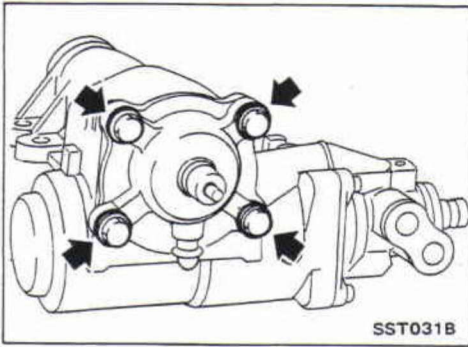

3. Draw out sector shaft.
Knock out end of sector shaft approximately 20 mm (0.79 in).

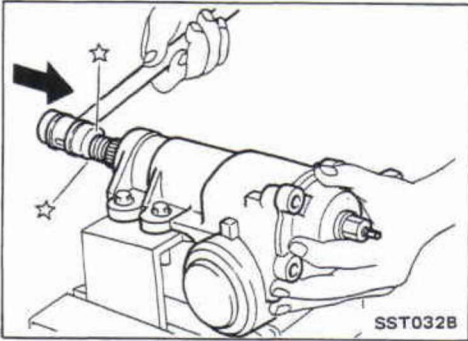

4. Pull out sector shaft by hand.
Attach plastic film to two bearings located inside gear housing while simultaneously pulling out sector shaft so that bearings will not drop into housing.

5. Remove gear housing dust seal.
6. Remove snap ring.
7. Remove back-up ring and oil seal.

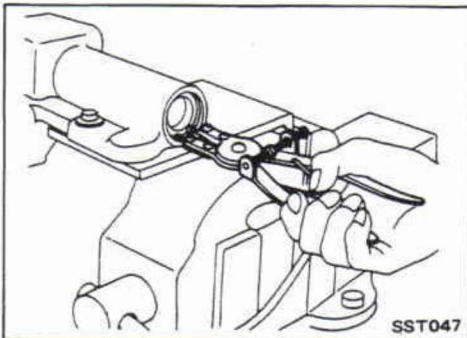

8. Remove O-ring.

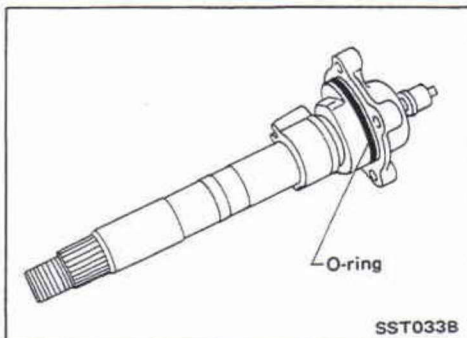

POWER STEERING GEAR (Model: PB56SC)

Disassembly (Cont'd) REAR HOUSING O-RING

1. Remove sector shaft.
2. Loosen (do not remove) rear housing bolts.

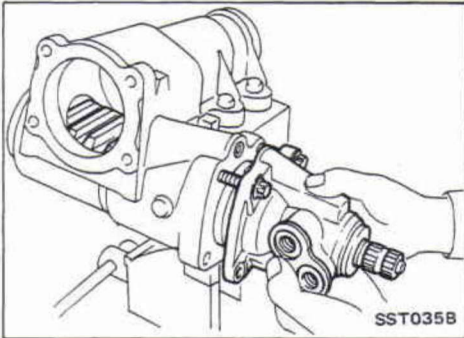
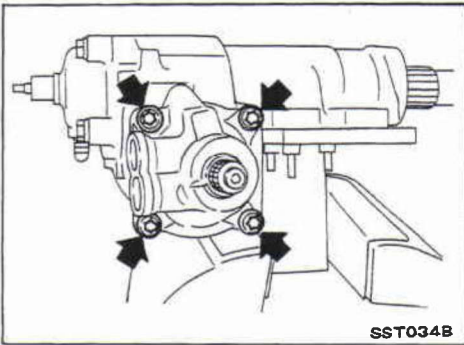

3. Remove rear housing together with worm gear assembly.

CAUTION:

- a. When worm assembly is removed, piston may turn and come off under its own weight. Hold piston to prevent it from turning.

If piston-to-rear housing clearance exceeds 22 mm (0.87 in) by loosening, recirculating ball will be out of groove of worm; do not reinstall piston but replace the entire assembly.

- b. Take care not to damage teflon ring at piston end when removing.

4. Remove Teflon ring and O-ring on worm and valve assembly.

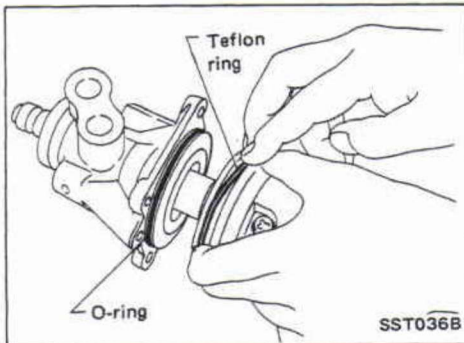

Assembly

1. Install new O-rings on gear housing.
 - Apply a thin coat of vaseline to new O-rings prior to their installation.
 - Be careful not to install wrong O-rings as some of them resemble in size.
 - Be careful not to separate worm and stub shaft.

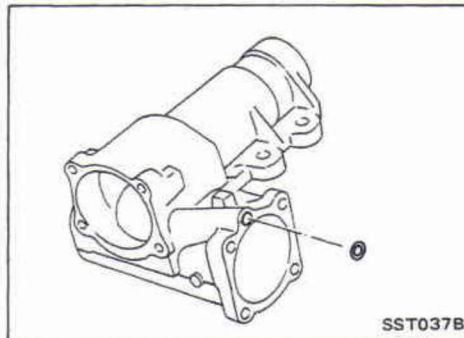

2. Install worm gear assembly with rear housing into gear housing.

CAUTION:

- Be careful that teflon ring on piston is not damaged during insertion of gear housing.
- When worm assembly is halfway inserted, teflon ring is deflected.
- Take care not to damage teflon ring on corner of sector hole.

Be sure that teflon ring settles in its correct position.

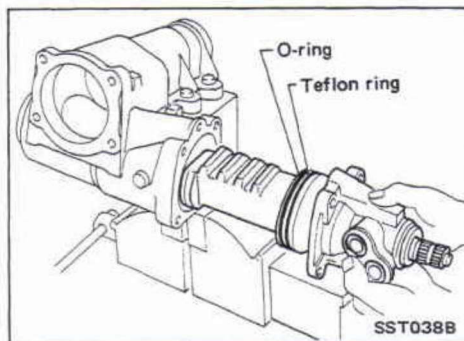

POWER STEERING GEAR (Model: PB56SC)

Assembly (Cont'd)

3. Gradually tighten rear housing bolts in a criss-cross fashion.

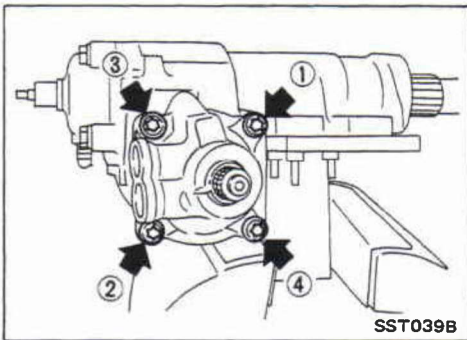

ADJUSTING SCREW LOCK NUT O-RING

Insert new O-ring into adjusting screw lock nut.

- Before inserting, apply a thin coat of vaseline to O-ring.
- Insert O-ring to make sure it fits into groove.

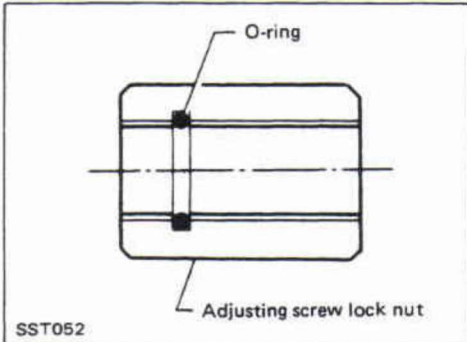

SECTOR SHAFT OIL SEAL

- When installing, be sure to use new oil seal, dust seal, back-up ring and snap ring.
- Before installing, apply a thin coat of vaseline to new oil seal and dust seal.

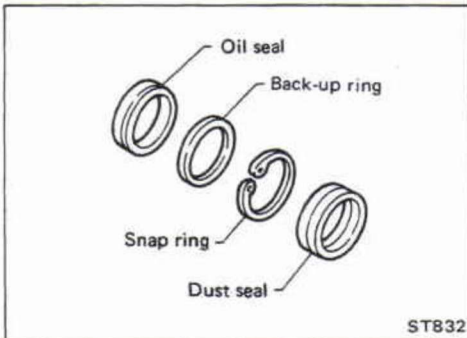

1. Press new oil seal and then install back-up ring with tool.

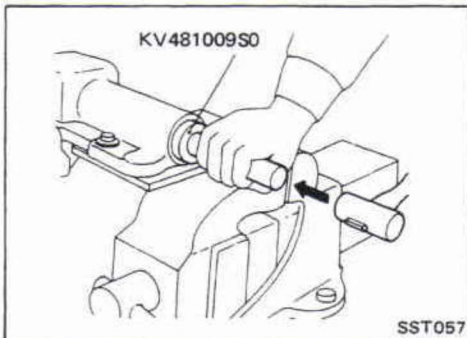

2. Install a new snap ring into gear housing.

CAUTION:

- Turn snap ring to make sure it fits into groove.
- Always install snap ring with R face facing inward.

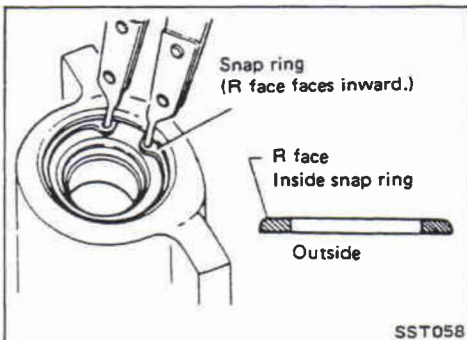

POWER STEERING GEAR (Model: PB56SC)

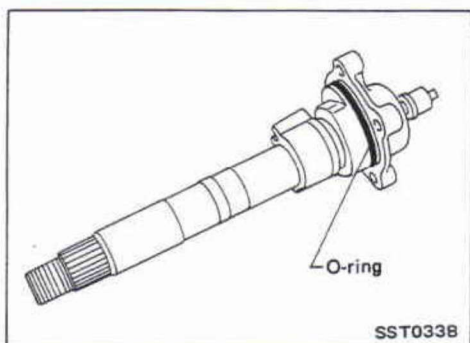

Assembly (Cont'd)

3. Fit new O-ring into sector shaft cover.
 - Before installing, apply a thin coat of vaseline to O-ring.
 - Make certain that O-ring is installed properly, and not damaged by sector shaft.

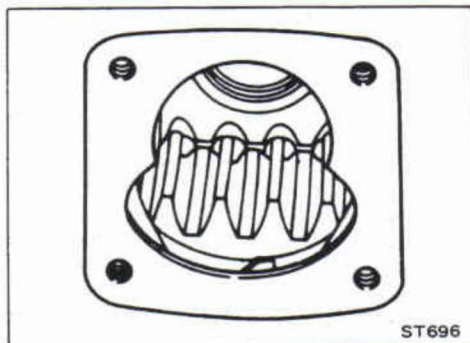

SECTOR SHAFT

1. Set piston rack at straight-ahead position.
Turn piston rack about 10° to 15° toward yourself with your finger.
This is for smooth insertion of sector gear.
2. Gradually insert sector shaft into gear housing.
When inserting sector shaft, simultaneously pull out plastic film so that bearings will not drop into housing.

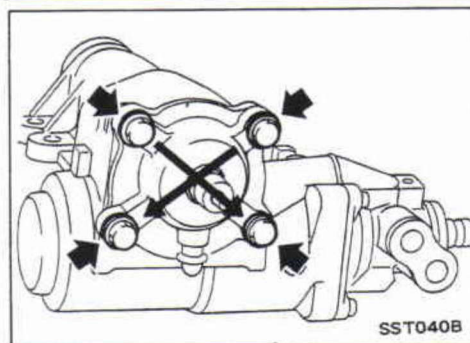

3. Tighten sector shaft cover bolts.
4. Check turning torque and steering gear preload.
Refer to Inspection and Adjustment.

Inspection and Adjustment

Before disassembling power steering gear component parts, make sure there is no oil leakage around sealing portion and check steering turning torque as follows.

Check sealing portion.

- Adjusting screw nut O-ring
- Sector shaft cover O-ring
- Sector shaft oil seal
- Rear cover oil seal and O-ring
- Rear housing O-ring
- Gear housing O-ring

Discard oil seal and O-ring which have once been removed.

Replace oil seal and O-ring if sealing is deformed or cracked.

POWER STEERING GEAR (Model: PB56SC)

Inspection and Adjustment (Cont'd)

TURNING TORQUE MEASUREMENT

1. Measure turning torque at 360° position.

(1) Install steering gear on Tool.

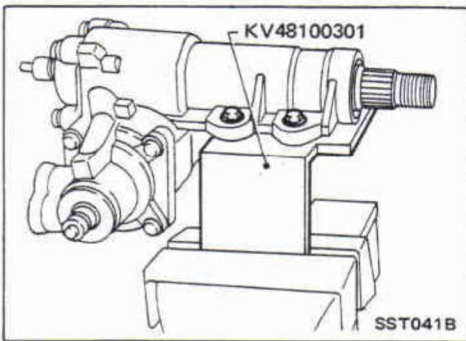

(2) Turn stub shaft all the way to right and left several times.

(3) Measure turning torque at 360° position from straight-ahead position with Tools.

Turning torque at 360°:

0.39 - 0.94 N·m (4 - 9.6 kg·cm, 3.5 - 8.3 in·lb)

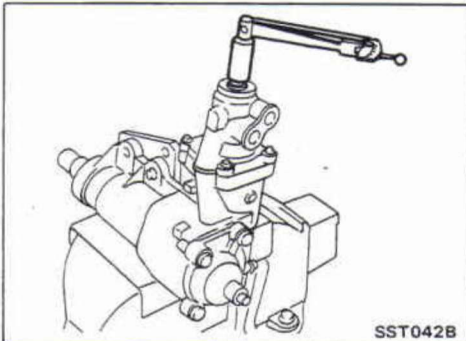

(4) Measure turning torque at straight-ahead position.

Straight-ahead position is a position where stub shaft is turned 2.14 turns (two-full turns and 50°) from lock position.

Turning torque at straight-ahead position:

0.2 - 0.4 N·m

(2 - 4 kg·cm, 1.7 - 3.5 in·lb) higher than at 360°

If they are not within specifications, adjust turning torque by turning sector shaft adjusting screw.

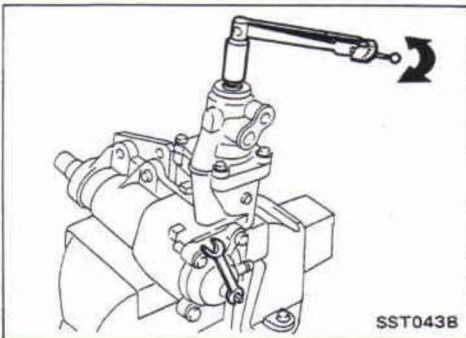

2. Tighten adjusting screw lock nut with tools.

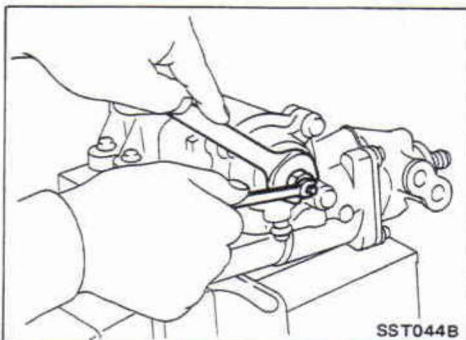

POWER STEERING OIL PUMP

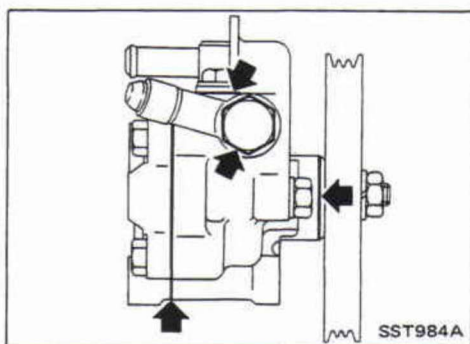

Pre-disassembly Inspection

Disassemble the power steering oil pump only if the following items are found.

- Oil leak from any point shown in the figure.
- Deformed or damaged pulley.

Disassembly

CAUTION:

- Parts which can be disassembled are strictly limited. Never disassemble parts other than those specified.
- Disassemble in as clean a place as possible.
- Clean your hands before disassembly.
- Do not use rags; use nylon cloths or paper towels.
- Follow the procedures and cautions in the Service Manual.
- When disassembling and reassembling, do not let foreign matter enter or contact the parts.
- Remove snap ring, then draw pulley shaft out. Be careful not to drop pulley shaft.

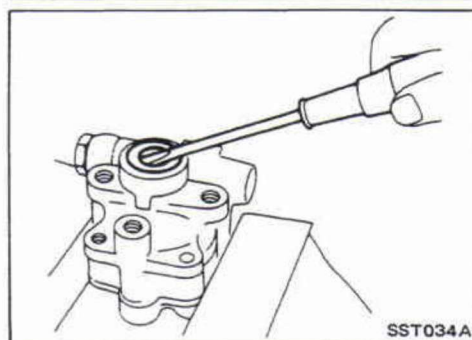
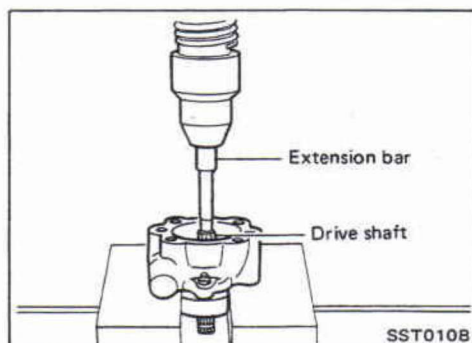
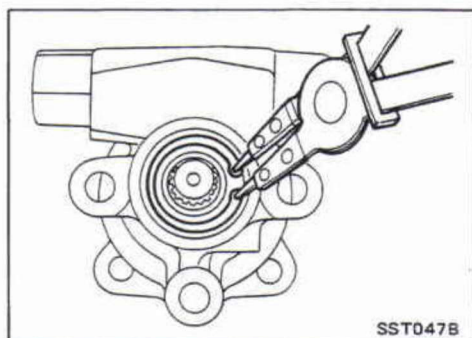

- Remove oil seal. Be careful not to damage front housing.

POWER STEERING OIL PUMP

Disassembly (Cont'd)

- Remove connector.
- Be careful not to drop spool.

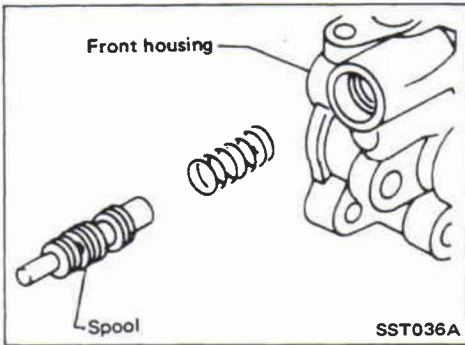

Inspection

PULLEY AND PULLEY SHAFT

- If pulley is cracked or deformed, replace it.
- If an oil leak is found around pulley shaft oil seal, replace the seal.
- If serration of pulley or pulley shaft is deformed or worn, replace it.

Assembly

Assemble oil pump in the reverse order of disassembly, noting the following instructions.

- Before installation, coat the O-rings and oil seal with A.T.F.*
 - Make sure O-rings and oil seal are properly installed.
 - When assembling vanes to rotor, rounded surfaces of vanes must face cam case side.
 - Always install new O-rings and oil seal.
 - Be careful of oil seal direction.
- *: Automatic Transmission Fluid

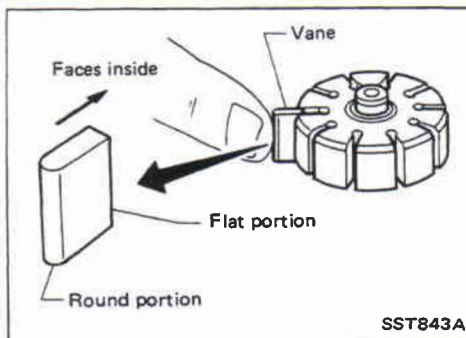
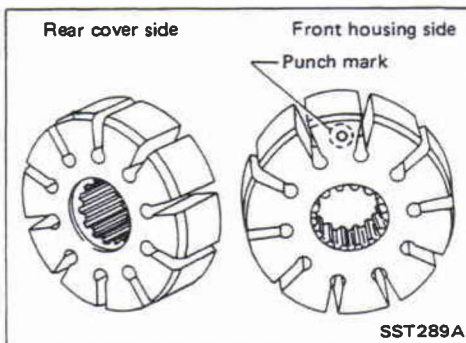
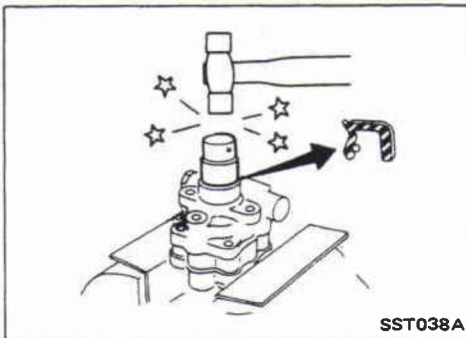

- Pay attention to the direction of rotor.
- Install vanes properly.

POWER STEERING OIL PUMP

Assembly (Cont'd)

CAUTION:

Do not remove spool valve from connector or connector bolt.

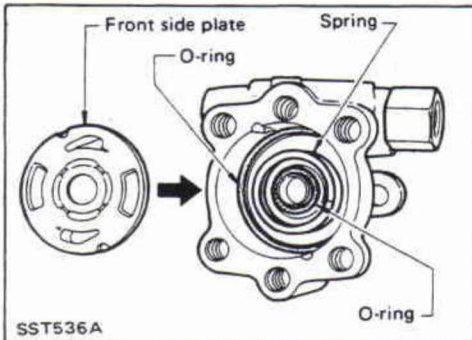
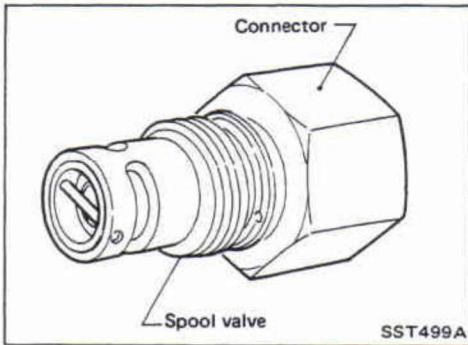

Model equipped with gasoline engine

- Apply A.T.F.* to O-ring.

*: Automatic Transmission Fluid

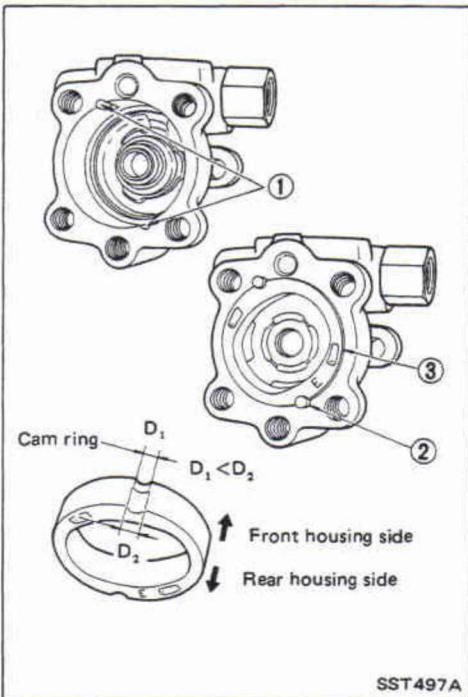

- Insert pin ② into pin groove ① of front housing and rotor. Then install cam ring ③ as shown at left.

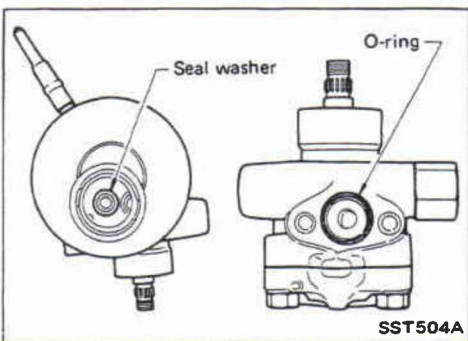

- Apply a coat of A.T.F. to O-ring.
- Be sure to install seal washer in its proper position.

STEERING LINKAGE

Hardtop & Wagon model

Removal and Installation

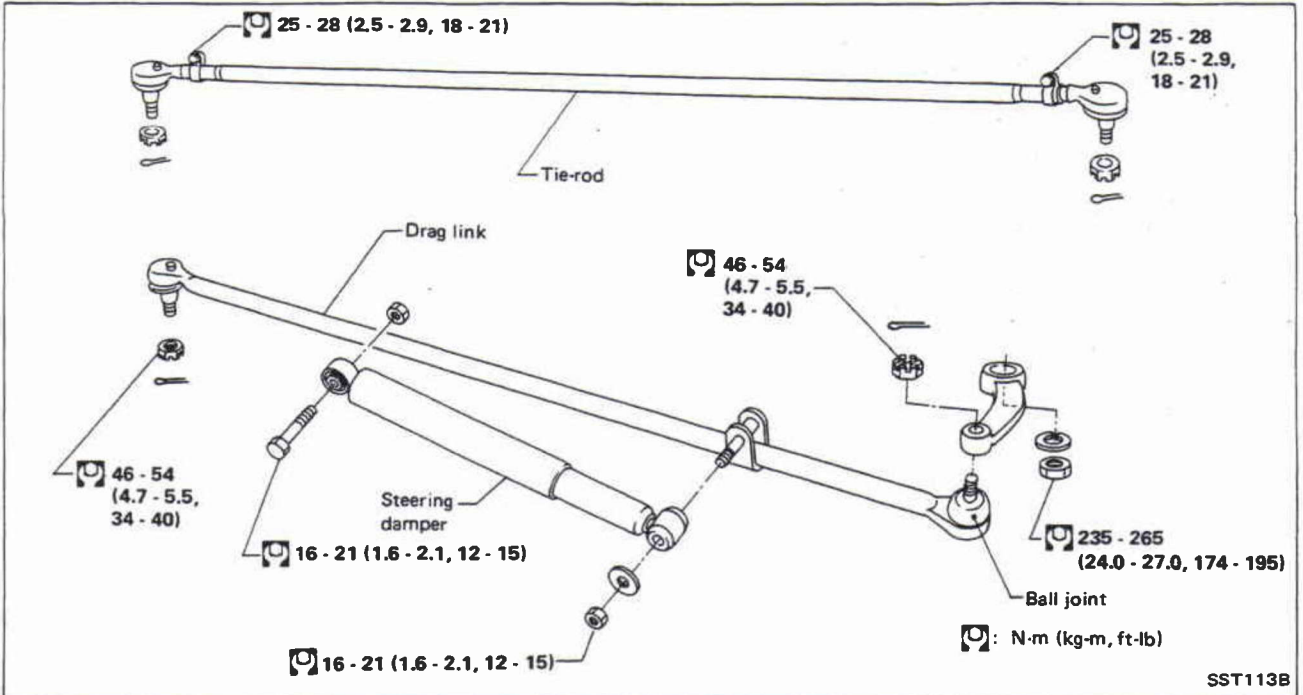

Pickup model

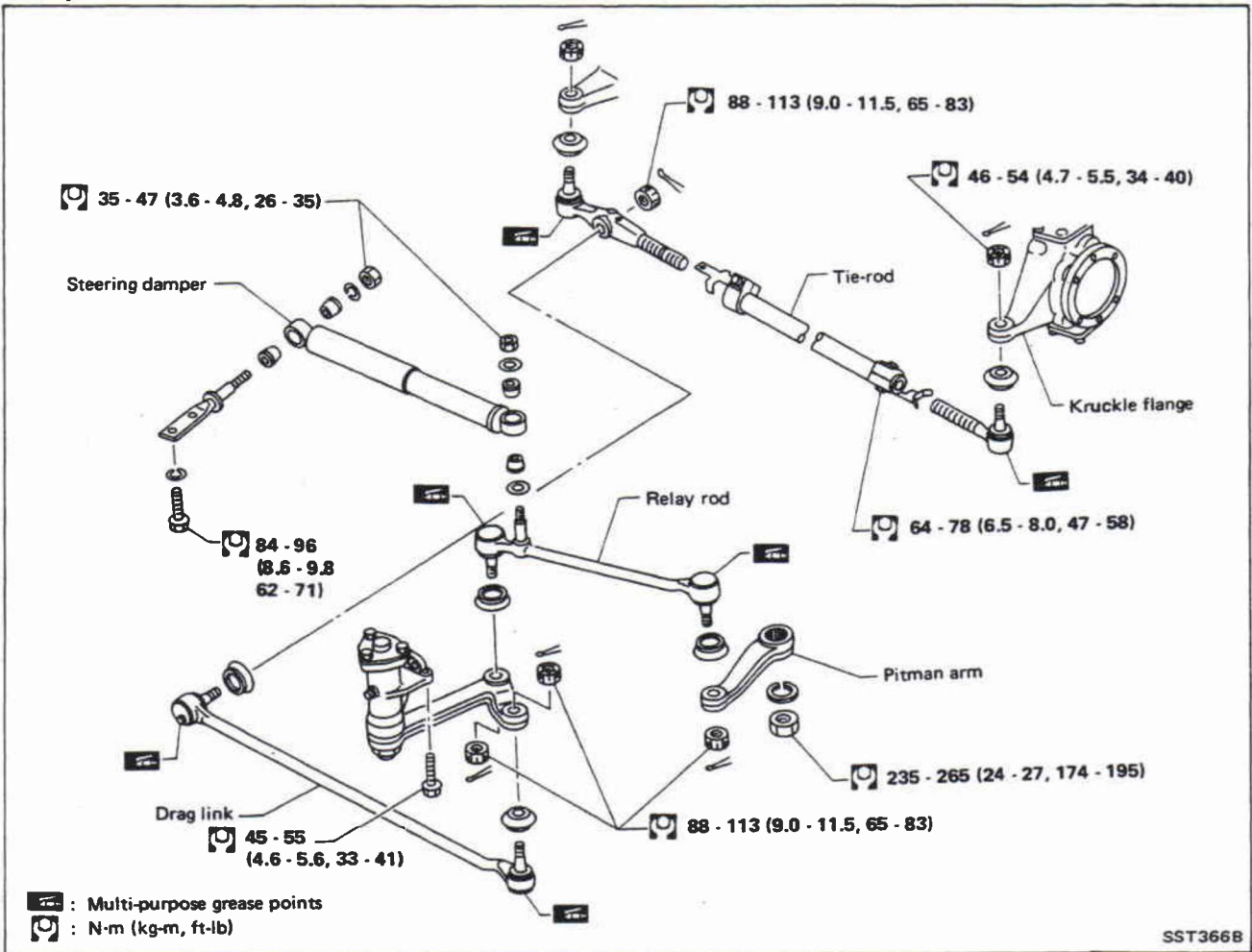

STEERING LINKAGE

Removal and Installation (Cont'd)

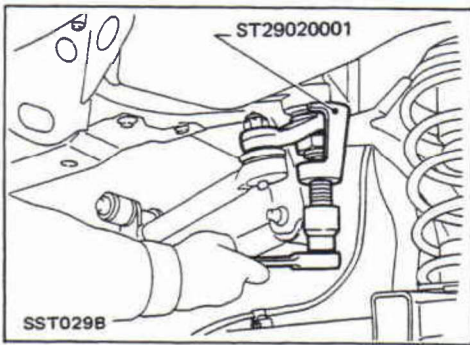

- Remove pitman arm with Tool.

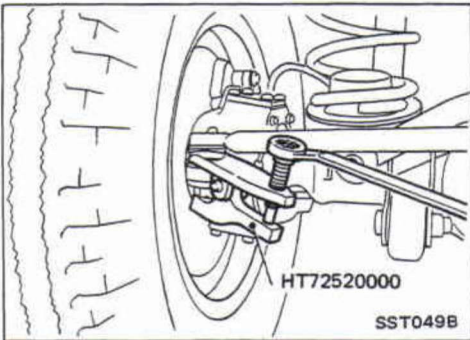

- Remove tie-rod with Tool.

Inspection

1. Check ball joint for play. If ball stud is worn and play in axial direction is excessive or joint is hard to swing, replace as a complete unit.

Swinging torque:

1.0 - 4.9 N·m
(10 - 50 kg-cm, 8.7 - 43.4 in-lb)

Rotating torque:

1.0 - 4.9 N·m
(10 - 50 kg-cm, 8.7 - 43.4 in-lb)

Axial end play:

1.3 mm (0.051 in) or less

2. Check condition of dust cover. If cracked excessively, replace it.
 - When replacing dust cover, be careful not to damage it.
 - Lubricate ball joint with multi-purpose grease, if necessary.

STEERING DAMPER

Check for oil leakage and measure damping force. Replace if necessary.

Damping force:

at 0.3 m (1.0 ft)/sec
3,629 N (370 kg, 816 lb)
... Extended direction
2,844 N (290 kg, 639 lb)
... Compressed direction

FIXING LOCATION

- Check nuts and cotter pins for looseness, play or breaks.
- When looseness or play is found, check for wear on tapered portion of ball stud.
- When reassembling each ball joint, use new cotter pins.

SERVICE DATA AND SPECIFICATIONS (S.D.S.)

General Specifications

Steering gear type	Manual steering		Power steering	
	VB70S		PB56SC	
Model	Wagon and Hardtop	Pickup	Wagon and Hardtop	Pickup
Turns of steering wheel on the vehicle (Lock-to-lock)	5.2	5.0	3.7	3.6
Steering gear ratio	24.4 - 26.8		17.0	
Steering damper [at 0.3 m (1.0 ft)/sec.] N (kg, lb)	3,629 (370, 816) ... Extended direction 2,844 (290, 639) ... Compressed direction			
Steering wheel axial play mm (in)	0 (0)			
Steering wheel play mm (in)	35 (1.38) or less			

Inspection and Adjustment

STEERING COLUMN

Destination	Middle East		Australia and general areas	
		Pickup		
Grade	DX	STD	DX	STD
Column type	Collapsible		Conventional	
	Tilt	Non-tilt	Tilt*	Non-tilt
Dimension "L" mm (in)	681.6 - 683.2 (26.83 - 26.90)		-	

*: Option for Australia Pickup model

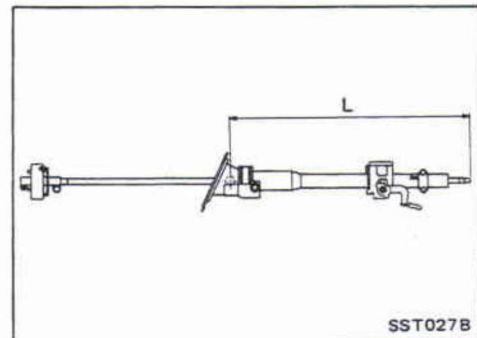

SERVICE DATA AND SPECIFICATIONS (S.D.S.)

Inspection and Adjustment (Cont'd)

MANUAL STEERING GEAR (Model: VB70S)

Worm bearing preload (Without oil seal) N·m (kg·cm, in·lb)	0.39 - 0.59 (4.0 - 6.0, 3.5 - 5.2)	
Steering gear preload (With oil seal) N·m (kg·cm, in·lb)		
New parts	0.83 - 1.23 (8.5 - 12.5, 7.4 - 10.9)	
Used parts	0.59 - 0.98 (6.0 - 10.0, 5.2 - 8.7)	
Backlash at pitman arm top end (in a straight- ahead position) mm (in)		
New gear	0 - 0.1 (0 - 0.004)	
Used gear	0 - 0.3 (0 - 0.012)	
End play (Between sector shaft and adjusting screw) mm (in)	0.01 - 0.03 (0.0004 - 0.0012)	
Adjusting shim thickness	Thickness mm (in)	Part number
	1.575 - 1.600 (0.0620 - 0.0630)	48213-B0100
	1.550 - 1.575 (0.0610 - 0.0620)	48214-B0100
	1.525 - 1.550 (0.0600 - 0.0610)	48215-B0100
	1.500 - 1.525 (0.0591 - 0.0600)	48216-B0100
	1.475 - 1.500 (0.0581 - 0.0591)	48217-B0100
	1.450 - 1.475 (0.0571 - 0.0581)	48218-B0100
Worm bearing shim thickness	Thickness mm (in)	Part number
	0.5 (0.020)	48273-82100
	0.2 (0.008)	48274-82100
	0.1 (0.004)	48275-82100
	0.075 (0.0030)	48276-82100
	0.05 (0.0020)	48277-82100
Oil capacity ℓ (Imp pt)	Approx. 0.5 (7/8)	

POWER STEERING SYSTEM (Model: PB56SC)

Steering wheel turning force (at 360° from neutral position and circumference of steering wheel) N (kg, lb)	39 (4, 9) or less	
Oil pump pressure kPa (bar, kg/cm ² , psi)	8,630 - 9,219 (86.3 - 92.2, 88 - 94, 1,251 - 1,337) at idling	
Fluid capacity mℓ (Imp fl oz)	Approx. 900 - 1,000 (31.7 - 35.2)	
Normal operating temperature °C (°F)	60 - 80 (140 - 176)	
Steering gear turning torque N·m (kg·cm, in·lb)		
360° position from straight-ahead position	0.39 - 0.94 (4 - 9.6, 3.5 - 8.3)	
Straight-ahead position (As compared with steering wheel turned 360°)	0.2 - 0.4 (2 - 4, 1.7 - 3.5) higher	
Backlash at pitman arm top end (in a straight- ahead position) mm (in)	0 - 0.1 (0 - 0.004)	
End play (Between sector shaft and adjusting screw) mm (in)	0.01 - 0.05 (0.0004 - 0.0020)	
Adjusting shim thickness	Thickness mm (in)	Part number
	1.575 - 1.600 (0.0620 - 0.0630)	48213-B0100
	1.550 - 1.575 (0.0610 - 0.0620)	48214-B0100
	1.525 - 1.550 (0.0600 - 0.0610)	48215-B0100
	1.500 - 1.525 (0.0591 - 0.0600)	48216-B0100
	1.475 - 1.500 (0.0581 - 0.0591)	48217-B0100
	1.450 - 1.475 (0.0571 - 0.0581)	48218-B0100

STEERING LINKAGE

Ball joint swinging force* N (kg, lb)	98 - 490 (10 - 50, 22 - 110)
Standard tie-rod length mm (in)	Approx. 1,270 (50.00)

*Measuring point: Cotter pin hole