

LIMITE DE PROPRIETE

LIMITE ZONAGE PPRI

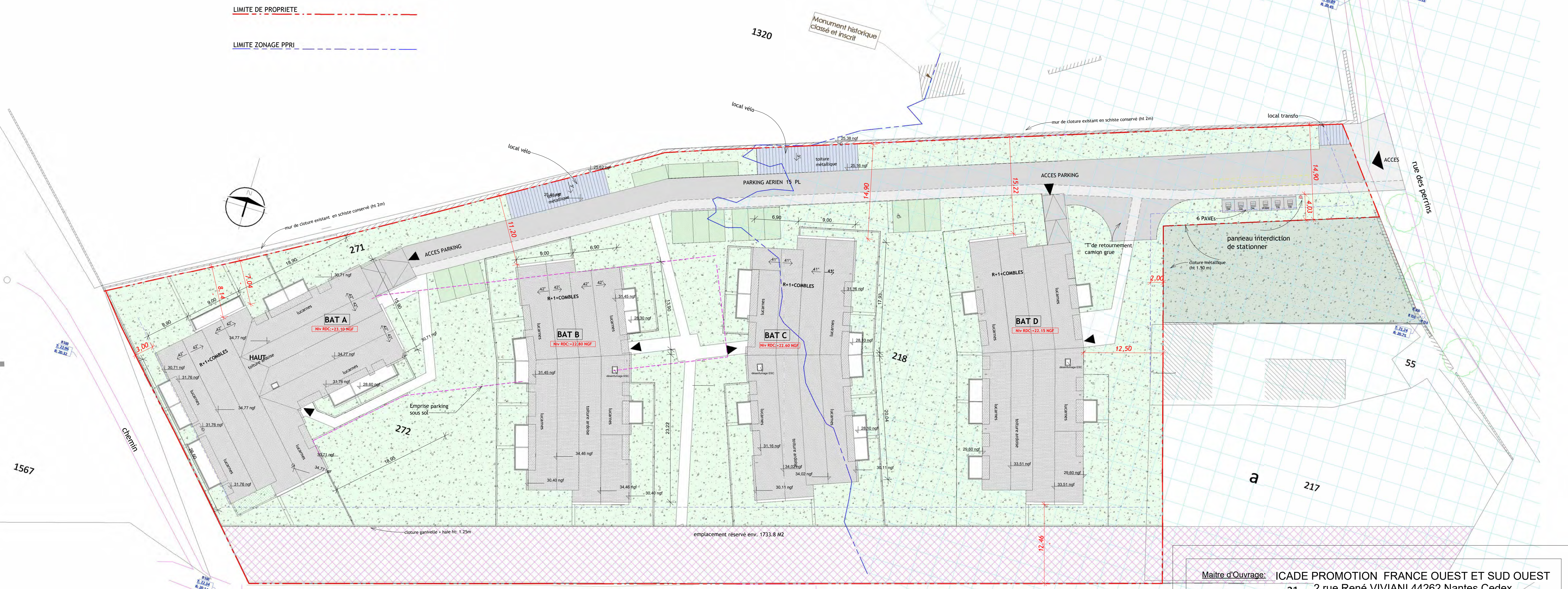

Maitre d'Ouvrage: **ICADE PROMOTION FRANCE OUEST ET SUD OUEST**  
 21 2 rue René VIVIANI 44262 Nantes Cedex



Opération: **CONSTRUCTION DE 101 LOGEMENTS**  
 Avenue Gallieni Les Ponts-de-cé

Ech: 1 : 300	<b>PLAN MASSE PROJET</b>	<b>PRO</b>
Date: 13/03/2023		<b>PRO-02</b>
C:\Users\rev\Documents\TERRE DE CE 14-03-2023_PRO_reunionRVGEY.rvt		Format: A1

Equipe de Maitrise d'Oeuvre		
ARCHITECTE	<b>ROLLAND &amp; ASSOCIES</b> S.E.L.A.S ROLLAND & ASSOCIES	53 Rue Troussaint BP 22431 49004 ANGERS CEDEX 02 Telephone: 02 41 88 13 34 www.rolland-associés.com
BET Structures	ETTEC	Technoparc de l'Aubinière Nantes (44) py.bouffort@ettec.org
BET Fluides/Thermique	NRGYS	07 Rue de Clisson, 44230 Saint-Sébastien-sur-Loire msauvêtre@nrgys.fr
BET Paysagiste	SICLE	1, Place Girard Languein - 49000 ANGERS Tel: 02 52 79 20 53 moe.paysage@sicla.net
BET VRD	AGEIS	20 Rue Marceau, 49100 Angers 02 52 35 23 30 c.chevalier@ages-ga.fr
BET Acoustique	DB ACOUSTIC	20, rue de la Chevalerie - 49000 Trélazé Tel: 02 41 87 21 26 / Port: 06 20 51 21 35 contact@dbacoustic.fr
Bureau de Contrôle	VERITAS	ANGERS - 2 rue Olivier de Serres, 49070 Beaucouz Tel: 06 78 43 77 25 mouhamadou-mahar.dou@veritas.com



# RESIDENCE "TERRES DE CE"

**& ROLLAND ASSOCIES**  
ARCHITECTURE  
URBANISME



ICADE PROMOTION FRANCE OUEST ET SUD OUEST  
2 rue René VIVIANI 44262 Nantes Cedex  
Tél : 02 22 35 02 02

**PDV - CELLIERS**

Date : 20/03/2023

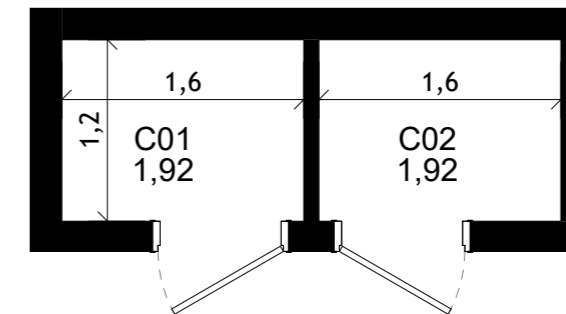
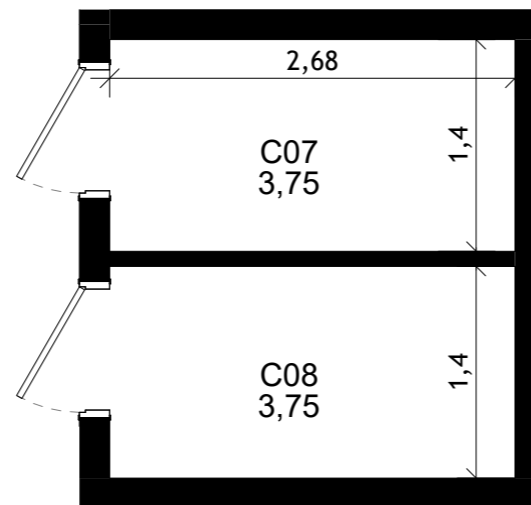
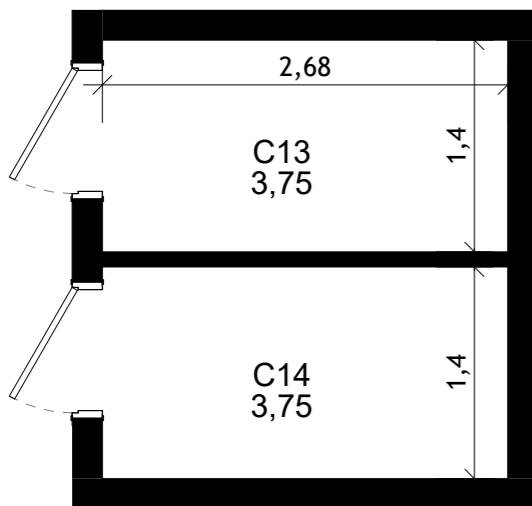
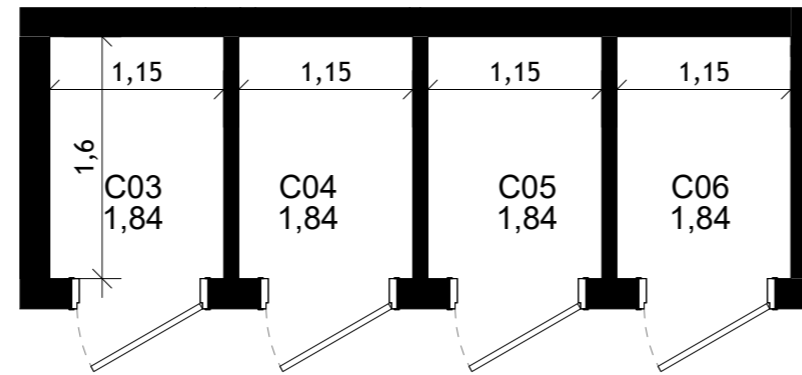
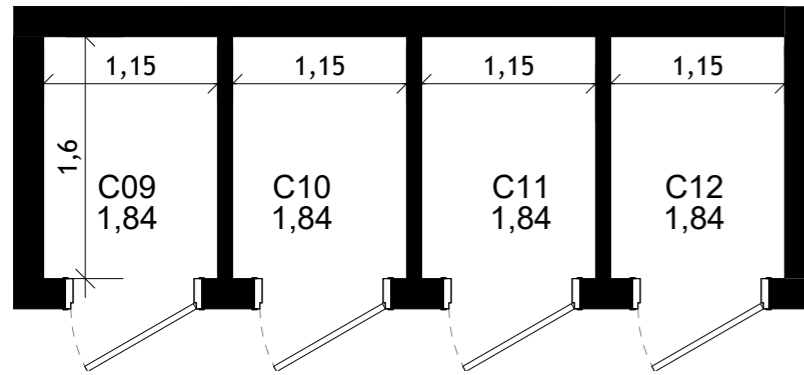

CELLIERS BATIMENT A - ICADE	
TYPE ANNEXE	SURFACE
C01	1,92 m <sup>2</sup>
C02	1,92 m <sup>2</sup>
C03	1,84 m <sup>2</sup>
C04	1,84 m <sup>2</sup>
C05	1,84 m <sup>2</sup>
C06	1,84 m <sup>2</sup>
C07	3,75 m <sup>2</sup>
C08	3,75 m <sup>2</sup>
C09	1,84 m <sup>2</sup>
C10	1,84 m <sup>2</sup>
C11	1,84 m <sup>2</sup>
C12	1,84 m <sup>2</sup>
C13	3,75 m <sup>2</sup>
C14	3,75 m <sup>2</sup>
<b>TOTAL SURFACE CELLIERS</b>	<b>33,57 m<sup>2</sup></b>

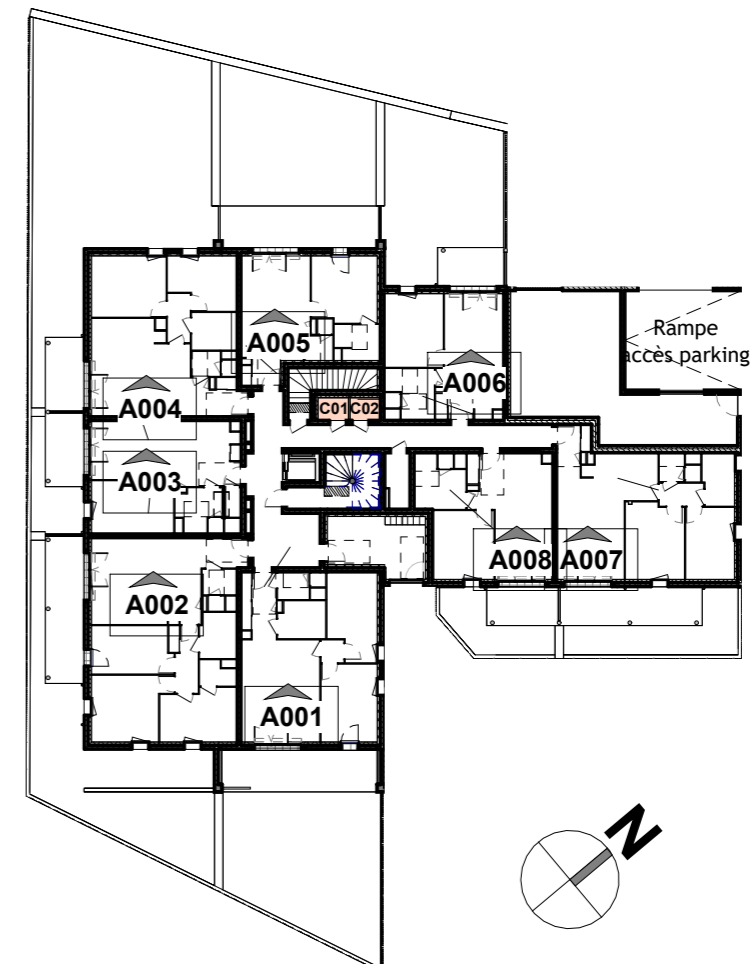
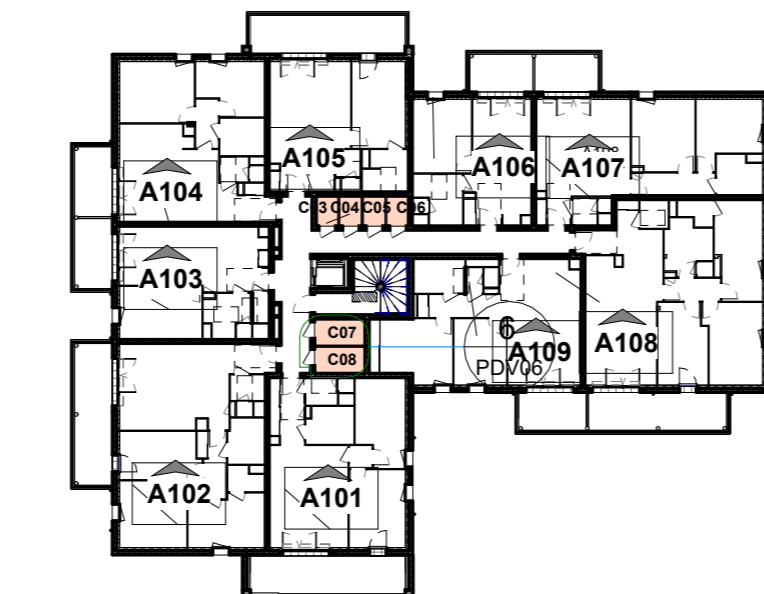
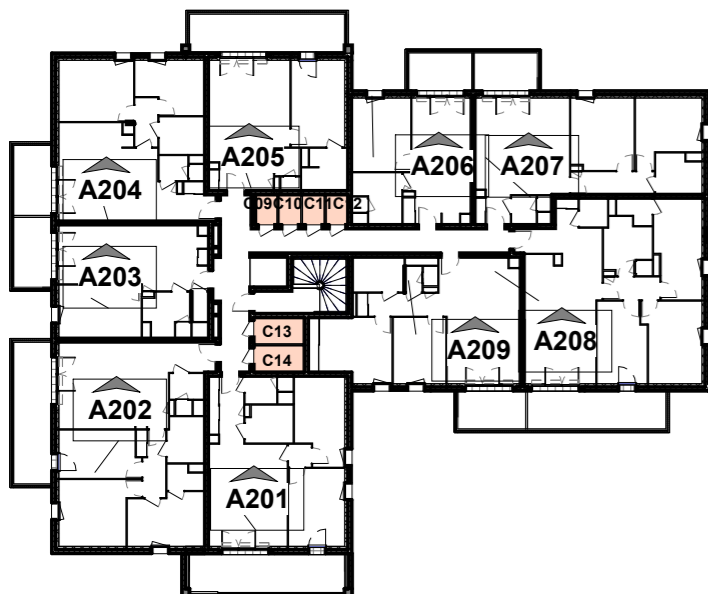

PLAN DE REPERAGE DES CELLIERS - PLAN R+2

PLAN DE REPERAGE DES CELLIERS - PLAN R+1

PLAN DE REPERAGE DES CELLIERS - PLAN RDC