

Allen screw M5X6  
T.C.E.I.  
Cod.201044

Db-Killer  $\phi$  22  
Cod.303430801

GP CORSA  
 $\phi$ i 54X240 RHS  
Cod.303457473

Knurled collar nut  
M8 Cod.200298

Silencer clamp  
Cod.303439501

Flange  
cod.206606

Welded bushing S.s  
cod.206608

OPTIONAL  
cod.5683

Allen screw M8X35  
T.C.E.I.Z.B.  
Cod.200319

Aluminium spacer  
 $\phi$ 22X8,5  
Cod. 205090

2x Short helical  
spring tensile  
cod. 303949001

Pipe N°1304 s.s  
cod. 309786203

Pipe N°1303 s.s  
cod. 309786201

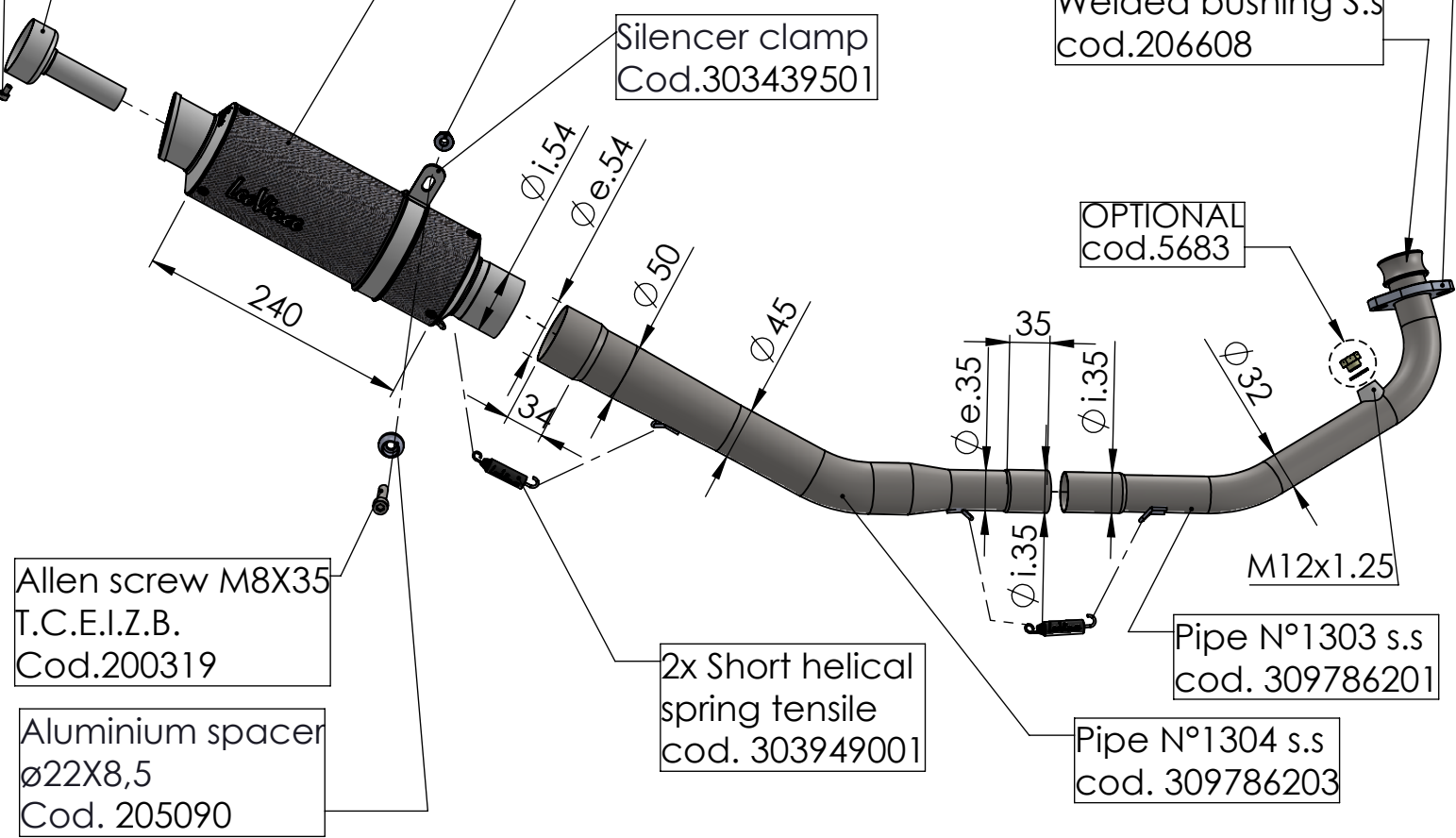

## WARNING

it is advisable to optimize the carburation by remapping the stock ECU or by adopting an additional ECU unit.

**ART. 9786**

HONDA WINNER 150 FI

FULL SYSTEM - GP CORSA - CARBON